

Operating Manual
SUNNY BOY STORAGE 2.5

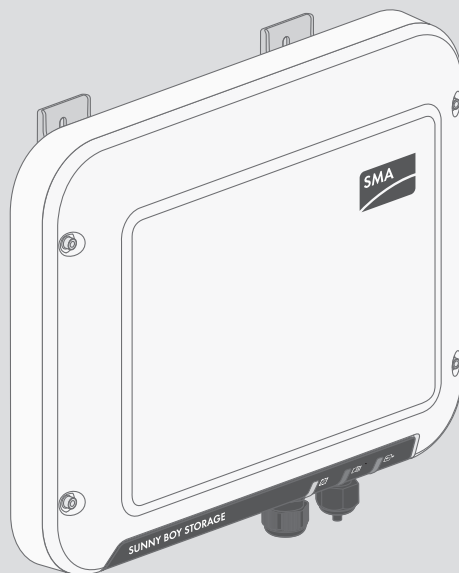

Legal Provisions

The information contained in these documents is property of SMA Solar Technology AG. Any publication, whether in whole or in part, requires prior written approval by SMA Solar Technology AG. Internal reproduction used solely for the purpose of product evaluation or other proper use is allowed and does not require prior approval.

SMA Warranty

You can download the current warranty conditions from the Internet at www.SMA-Solar.com.

Software licenses

The licenses for the used software modules can be called up on the user interface of the product.

Trademarks

All trademarks are recognized, even if not explicitly identified as such. Missing designations do not mean that a product or brand is not a registered trademark.

Modbus[®] is a registered trademark of Schneider Electric and is licensed by the Modbus Organization, Inc.

QR Code is a registered trademark of DENSO WAVE INCORPORATED.

Phillips[®] and Pozidriv[®] are registered trademarks of Phillips Screw Company.

Torx[®] is a registered trademark of Acument Global Technologies, Inc.

SMA Solar Technology AG

Sonnenallee 1

34266 Niestetal

Germany

Tel. +49 561 9522-0

Fax +49 561 9522-100

www.SMA.de

Email: info@SMA.de

Status: 5/22/2017

Copyright © 2017 SMA Solar Technology AG. All rights reserved.

Table of Contents

1	Information on this Document	6
1.1	Validity	6
1.2	Target Group	6
1.3	Structure	6
1.4	Symbols	6
1.5	Additional Information.....	7
1.6	Nomenclature	8
1.7	Typographies	8
2	Safety	9
2.1	Intended Use.....	9
2.2	Safety Information	10
3	Scope of Delivery	11
4	Product Description	12
4.1	Sunny Boy Storage.....	12
4.2	Interfaces and Functions.....	15
4.3	LED Signals	16
4.4	System Structure.....	17
5	Mounting.....	21
5.1	Requirements for Mounting.....	21
5.2	Mounting the Inverter	23
6	Electrical Connection	26
6.1	Overview of the Connection Area.....	26
6.2	AC Connection	26
6.2.1	Requirements for the AC Connection	26
6.2.2	Connecting the Inverter to the Utility Grid	28
6.2.3	Connecting Additional Grounding	30
6.3	DC Connection	31
6.3.1	Assembling the DC Connectors.....	31
6.3.2	Connecting the Power Cable of the Battery	33
6.3.3	Disassembling the DC Connectors	35

6.4	Connecting the Network and Energy Meter	36
6.5	Connecting the Data Cable of the Battery.....	39
7	Commissioning	43
7.1	Commissioning Procedure.....	43
7.2	Commissioning the Inverter	43
7.3	Selecting a configuration option.....	44
7.4	Starting the Self-Test (For Italy Only).....	47
8	Using the Inverter User Interface.....	48
8.1	Establishing a connection to the user interface.....	48
8.1.1	Establishing a direct connection via WLAN.....	48
8.1.2	Establishing a Direct Connection via Ethernet	49
8.1.3	Establishing a Connection via Ethernet in the local network	50
8.2	Logging In and Out of the User Interface	51
8.3	Start Page Design of the User Interface	53
8.4	Changing the Password	57
9	Configuration of the Inverter.....	58
9.1	Changing Operating Parameters	58
9.2	Starting the Installation Assistant	59
9.3	Configuring the Country Data Set	60
9.4	Configuring Feed-In Management	60
9.5	Configuring the Modbus Function	62
9.6	Saving the Configuration in a File	63
9.7	Adopting a Configuration from a File	63
9.8	Activate WPS Function	63
9.9	Switching WLAN On and Off	64
9.10	Activating the Receipt of Control Signals (Only for Italy)	64
9.11	Deactivating Grounding Conductor Monitoring	65
9.12	Configuring the Energy Meter	65
9.13	Setting the heating mode for the battery.....	66
10	Disconnecting the Inverter from Voltage Sources	67
11	Cleaning the Inverter	70

12 Troubleshooting	71
12.1 Forgiven Password.....	71
12.2 Event Messages.....	72
12.3 Updating the Firmware	96
13 Decommissioning the Inverter	98
14 Spare Parts	101
15 Technical Data	102
16 Contact	106
17 EU Declaration of Conformity	108

1 Information on this Document

1.1 Validity

This document is valid for the device type "SBS2.5-1VL-10" (Sunny Boy Storage 2.5) from firmware version 02.04.19.R.

1.2 Target Group

This document is intended for qualified persons and end users. Only qualified persons are allowed to perform the activities marked in this document with a warning symbol and the caption "Qualified person". Tasks that do not require any particular qualification are not marked and can also be performed by end users. Qualified persons must have the following skills:





- Knowledge of how an inverter and lithium-ion batteries work and are operated
- Training in how to deal with the dangers and risks associated with installing and using electrical devices, lithium-ion batteries and systems
- Training in the installation and commissioning of electrical devices and installations
- Knowledge of the applicable standards and directives
- Knowledge of and compliance with this document and all safety information
- Knowledge of and compliance with the documents of the battery manufacturer with all safety information



1.3 Structure

This document describes the mounting, installation, commissioning, configuration, operation, troubleshooting and decommissioning of the product as well as the operation of the product user interface.

You will find the latest version of this document and further information on the product in PDF format at www.SMA-Solar.com.

1.4 Symbols

Symbol	Explanation
 DANGER	Indicates a hazardous situation which, if not avoided, will result in death or serious injury
 WARNING	Indicates a hazardous situation which, if not avoided, can result in death or serious injury
 CAUTION	Indicates a hazardous situation which, if not avoided, can result in minor or moderate injury
NOTICE	Indicates a situation which, if not avoided, can result in property damage
 QUALIFIED PERSON	Sections describing activities to be performed by qualified persons only

Symbol	Explanation
	Information that is important for a specific topic or goal, but is not safety-relevant
<input type="checkbox"/>	Indicates a requirement for meeting a specific goal
<input checked="" type="checkbox"/>	Desired result
	A problem that might occur

1.5 Additional Information

Links to additional information can be found at www.SMA-Solar.com:

Document title	Document type
"Overview of approved lithium-ion batteries" Overview of approved lithium-ion batteries	Technical Information
"Efficiency and Derating" Efficiency and Derating Behavior of the Sunny Boy, Sunny Tripower and Sunny Mini Central Inverters	Technical Information
"Criteria for Selecting a Residual-Current Device" Criteria for Selecting a Residual-Current Device	Technical Information
"Circuit Breaker" Dimensioning and Selection of a Suitable AC Circuit Breaker for Inverters under PV-Specific Influences	Technical Information
"Application for SMA Grid Guard Code"	Form
"Webconnect Systems in Sunny Portal" Registration in Sunny Portal	User Manual
"SMA Modbus® Interface" Information on the commissioning and configuration of the SMA Modbus interface	Technical Information
"SunSpec® Modbus® Interface" Information on the commissioning and configuration of the SunSpec Modbus interface	Technical Information
"SMA Modbus® Interface" List with the product specific SMA Modbus registers	Technical Information
"SunSpec® Modbus® Interface" List with the product specific SunSpec Modbus registers	Technical Information
"Parameters and Measured Values" Overview of All Inverter Operating Parameters and Their Configuration Options	Technical Information

1.6 Nomenclature

Complete designation	Designation in this document
Sunny Boy Storage	Inverter, product

1.7 Typographies

Typography	Use	Example
bold	<ul style="list-style-type: none"> Terminals Slots Parameters Elements on the user interface Elements to be selected Elements to be entered 	<ul style="list-style-type: none"> The value can be found in the field Energy. Select Settings. Enter 10 in the field Minutes.
>	<ul style="list-style-type: none"> Connects several elements to be selected 	<ul style="list-style-type: none"> Select Settings > Date.
[Button]	<ul style="list-style-type: none"> Button to be selected or pressed 	<ul style="list-style-type: none"> Select [Next].

2 Safety

2.1 Intended Use

The Sunny Boy Storage is a single-phase, AC coupled battery inverter for parallel grid operation. The Sunny Boy Storage converts the direct current supplied by a battery into grid-compliant alternating current. With a lithium-ion battery and the energy meter, the Sunny Boy Storage becomes a system for increased self-consumption.

The Sunny Boy Storage must only be operated in connection with an intrinsically safe lithium-ion battery approved by SMA Solar Technology AG. An updated list of batteries approved by SMA Solar Technology AG is available at www.SMA-Solar.com.

The lithium-ion battery must comply with the locally applicable standards and directives and must be intrinsically safe (see technical information "SMA Flexible Storage System - Detailed explanations of the safety concept" for detailed explanations regarding the safety concept of battery inverters by SMA Solar Technology AG). The battery management of the used lithium-ion battery must be compatible with the Sunny Boy Storage. The entire battery voltage range must be completely within the permissible input voltage range of the Sunny Boy Storage. The maximum permissible DC input voltage of the Sunny Boy Storage must not be exceeded.

The Sunny Boy Storage is suitable for indoor and outdoor use.

The Sunny Boy Storage is not suitable for supplying life-sustaining medical devices. A power outage must not lead to personal injury.

All components must remain within their permitted operating ranges and their installation requirements at all times.

The product must only be used in countries for which it is approved or released by SMA Solar Technology AG and the grid operator.

The product is also approved for the Australian market and may be used in Australia. If DRM support is specified, the inverter may only be used in conjunction with a Demand Response Enabling Device (DRED). This ensures that the inverter implements the commands from the grid operator for active power limitation at all times. The inverter and the Demand Response Enabling Device (DRED) must be connected in the same network and the inverter Modbus interface must be activated and the TCP server set.

Use this product only in accordance with the information provided in the enclosed documentation and with the locally applicable standards and directives. Any other application may cause personal injury or property damage.

Alterations to the product, e.g. changes or modifications, are only permitted with the express written permission of SMA Solar Technology AG. Unauthorized alterations will void guarantee and warranty claims and in most cases terminate the operating license. SMA Solar Technology AG shall not be held liable for any damage caused by such changes.

Any use of the product other than that described in the Intended Use section does not qualify as the intended use.

The enclosed documentation is an integral part of this product. Keep the documentation in a convenient place for future reference and observe all instructions contained therein.

The type label must remain permanently attached to the product.

2.2 Safety Information

This section contains safety information that must be observed at all times when working on or with the product.

To prevent personal injury and property damage and to ensure long-term operation of the product, read this section carefully and observe all safety information at all times.

⚠ DANGER

Danger to life from electric shock due to live DC cables at the battery.

The DC cables connected to a battery are live. Touching the DC conductors or the live components leads to lethal electric shocks.

- Do not touch non-insulated cable ends.
- Do not touch the DC conductors.
- Do not touch any live components.
- Have the inverter and the battery mounted, installed and commissioned only by qualified persons with the appropriate skills.
- Observe all safety information of the battery manufacturer.
- Prior to performing any work on the inverter or the battery, disconnect the inverter from all voltage sources as described in this document.
- If an error occurs, have it rectified by qualified persons only.

⚠ WARNING

Risk of injury due to short-circuit currents

Short-circuit currents in the battery can cause heat build-up and electric arcs. Burns or eye injuries due to flashes may result.

- Remove watches, rings and other metal objects.
- Use insulated tools.
- Do not place tools or metal parts on the battery.

⚠ CAUTION

Risk of burns due to hot enclosure parts

Some parts of the enclosure can get hot during operation.

- Mount the inverter in such a way that it cannot be touched inadvertently during operation.

NOTICE

Damage to the inverter due to the use of cleaning agents

- If the inverter is dirty, clean the enclosure, the enclosure lid, the type label and the LEDs using only clean water and a cloth.

3 Scope of Delivery

Check the scope of delivery for completeness and any externally visible damage. Contact your distributor if the scope of delivery is incomplete or damaged.

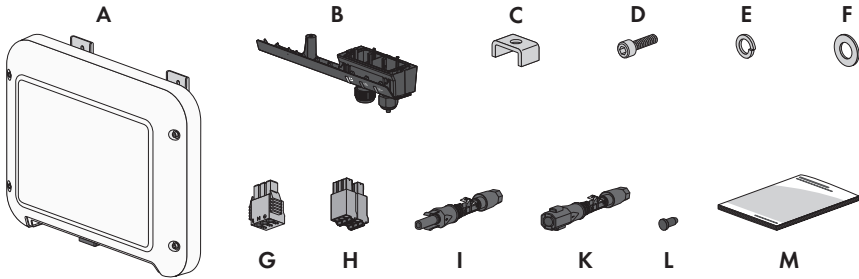

Figure 1: Components included in the scope of delivery

Position	Quantity	Designation
A	1	Inverter
B	1	Connection cap
C	1	Clamping bracket
D	1	Cylindrical screw M5x16
E	1	Spring lock washer
F	1	Washer
G	1	Connecting terminal plate for the AC connection
H	1	Plug for the battery communication connection
I	1	Positive DC connector
K	1	Negative DC connector
L	2	Sealing plug
M	1	Quick reference guide with password label on the rear side The label contains the following information: <ul style="list-style-type: none"> • PIC (Product Identification Code) identification key for registering the system in Sunny Portal • RID (Registration Identifier) registration ID for registering the system in Sunny Portal • WLAN password WPA2-PSK (WiFi Protected Access 2 - Preshared Key) for direct connection to the inverter via WLAN

4 Product Description

4.1 Sunny Boy Storage

The Sunny Boy Storage is a single-phase, AC coupled battery inverter for parallel grid operation. The Sunny Boy Storage converts the direct current supplied by a battery into grid-compliant alternating current. With a lithium-ion battery and the energy meter, the Sunny Boy Storage becomes a system for increased self-consumption.

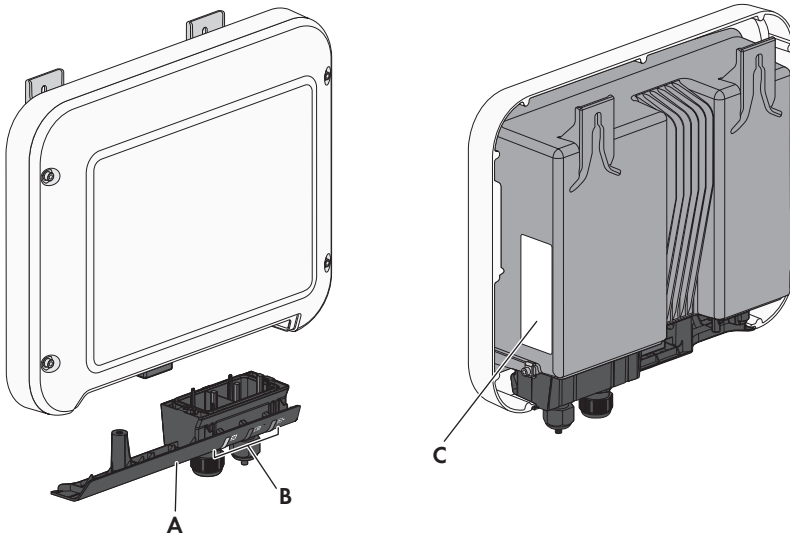

















Figure 2: Design of the Sunny Boy Storage



Position	Designation
A	Connection cap
	Connection area with cable glands for connection to the utility grid, the battery communication cable and a network cable

Position	Designation
B	LEDs The LEDs indicate the operating state of the inverter.
C	Type label The type label uniquely identifies the inverter. The type label must remain permanently attached to the product. You will find the following information on the type label: <ul style="list-style-type: none"> • Device type (Model) • Serial number (Serial No.) • Date of manufacture • Identification key (PIC) for registration in Sunny Portal • Registration ID (RID) for registration in Sunny Portal • WLAN password WPA2-PSK (WiFi Protected Access 2 - Preshared Key) for direct connection to the inverter via WLAN • Device-specific characteristics

Symbols on the Inverter and on the Type Label

Symbol	Explanation
	Inverter Together with the green LED, this symbol indicates the operating state of the inverter.
	Observe the documentation Together with the red LED, this symbol indicates an error.
	Data transmission Together with the blue LED, this symbol indicates the status of the network connection.
	Grounding conductor This symbol indicates the position for connecting a grounding conductor.
	Danger to life due to high voltages in the inverter; observe a waiting time of 5 minutes High voltages that can cause lethal electric shocks are present in the live components of the inverter. Prior to performing any work on the inverter, disconnect it from all voltage sources as described in this document.

Symbol	Explanation
	Risk of burns due to hot surfaces The product can get hot during operation. Avoid contact during operation. Prior to performing any work on the product, allow the product to cool down sufficiently.
	Danger to life due to electric shock The product operates at high voltages. Prior to performing any work on the product, disconnect the product from voltage sources. All work on the product must be carried out by qualified persons only.
	Observe the documentation Observe all documentation supplied with the product.
	Danger This symbol indicates that the inverter must be additionally grounded if additional grounding or equipotential bonding is required at the installation site.
	Direct current
	The product is has no galvanic isolation.
	Alternating current
	WEEE designation Do not dispose of the product together with the household waste but in accordance with the disposal regulations for electronic waste applicable at the installation site.
	CE marking The product complies with the requirements of the applicable EU directives.
	Degree of protection IP65 The product is protected against dust intrusion and water jets from any angle.
	The product is suitable for outdoor installation.

Symbol	Explanation
	<p>ICASA</p> <p>The product complies with the requirements of the South African standards for telecommunication.</p>
	<p>ANATEL</p> <p>The product complies with the requirements of the Brazilian standards for telecommunication.</p> <p>Este equipamento opera em caráter secundário, isto é, não tem direito a proteção contra interferência prejudicial, mesmo de estações do mesmo tipo, e não pode causar interferência a sistemas operando em caráter primário.</p>

4.2 Interfaces and Functions

The inverter is equipped with the following interfaces and functions:

User interface for the monitoring and configuration of the inverter

The inverter is standard-equipped with an integrated web server, which provides a user interface for configuring and monitoring the inverter. The inverter user interface can be called up via the web browser if there is an existing WLAN or Ethernet connection to a computer, tablet PC or smartphone.

SMA Speedwire

The inverter is equipped with SMA Speedwire as standard. SMA Speedwire is a type of communication based on the Ethernet standard. This enables inverter-optimized 10 or 100 Mbit data transmission between Speedwire devices in PV systems and the user interface of the inverter.

SMA Webconnect

The inverter is equipped with a Webconnect function as standard. The Webconnect function enables direct data transmission between the inverters of a small-scale system and the Internet portal Sunny Portal without any additional communication device and for a maximum of 4 inverters per Sunny Portal system. If there is an existing WLAN or Ethernet connection, you can directly access your Sunny Portal system via the web browser on the computer, tablet PC or smartphone.

WLAN

The inverter is equipped with a WLAN interface as standard. The inverter is delivered with the WLAN interface activated as standard. If you do not want to use WLAN, you can deactivate the WLAN interface.

In addition, the inverter has a WPS (WiFi Protected Setup) function. The WPS function is for automatically connecting the inverter to a device in the same network as the inverter (e.g. router, computer, tablet PC or smartphone).

Limited function in the event of frost

The integrated WLAN interface is only designed for temperatures down to -20°C .

- Deactivate the WLAN interface at low temperatures (see Section 9.9 "Switching WLAN On and Off", page 64).

Modbus

The inverter is equipped with a Modbus interface. The Modbus interface is deactivated by default and must be configured as needed.

The Modbus interface of the supported SMA devices is designed for industrial use and has the following tasks:

- Remote query of measured values
- Remote setting of operating parameters
- Setpoint specifications for system control

Grid Management Services

The inverter is equipped with service functions for grid management.

Depending on the requirements of the grid operator, you can activate and configure the functions (e.g. active power limitation) via operating parameters.

All-pole sensitive residual-current monitoring unit

The all-pole sensitive residual-current monitoring unit detects alternating and direct differential currents. In single-phase and three-phase inverters, the integrated differential current sensor detects the current difference between the neutral conductor and the line conductor(s). If the current difference increases suddenly, the inverter disconnects from the utility grid.

4.3 LED Signals

The LEDs indicate the operating state of the inverter.

LED	Status	Explanation
Green LED	flashing: 2 s on 2 s off	Waiting for connection conditions The conditions for feed-in operation are not yet met. As soon as the conditions are met, the inverter will start feed-in operation.
	flashing quickly	Update of central processing unit The central processing unit of the inverter is being updated.
	glowing	Parallel grid operation
Red LED	glowing	Event occurred If an event occurs, a distinct event message and the corresponding event number will be displayed in addition on the inverter user interface or in the communication product.

LED	Status	Explanation
Blue LED	flashes slowly for approx. one minute	Communication connection is being established The inverter is establishing a connection to a local network or is establishing a direct connection to an end device via Ethernet (e.g. computer, tablet PC or smartphone).
	flashes quickly for approx. two minutes	WPS active The WPS function is active.
	glowing	Communication active There is an active connection with a local network or there is a direct connection with an end device via Ethernet (e.g. computer, tablet PC or smartphone).

4.4 System Structure

SMA Flexible Storage System without Sunny Home Manager

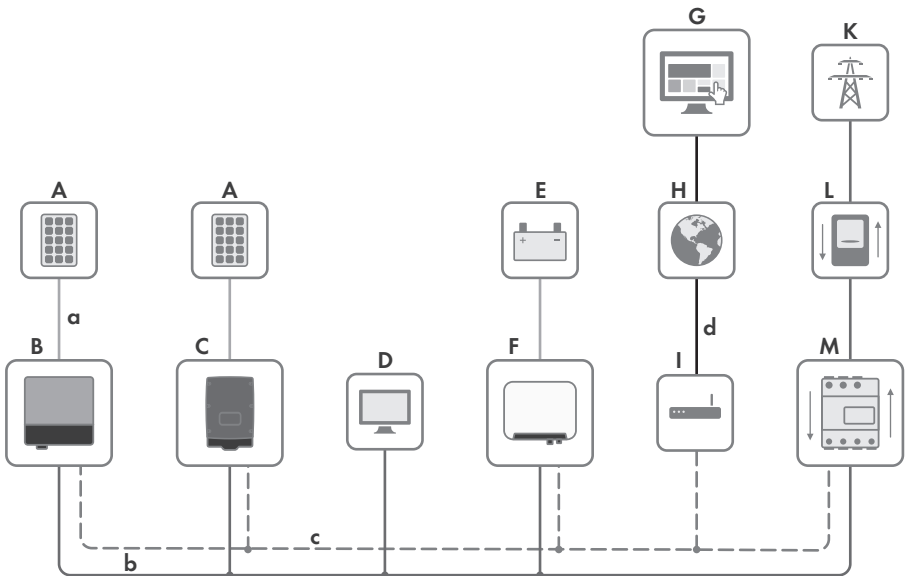

Figure 3: Overview of a system with Sunny Boy Storage and Energy Meter (example)

Position	Designation
A	PV array
B	PV inverter with SMA Speedwire/Webconnect (single-phase)

Position	Designation
C	PV inverter with SMA Speedwire/Webconnect (three-phase)
D	Loads
E	Battery
F	Sunny Boy Storage
G	Sunny Portal
H	Internet
I	Router/network switch
K	Utility grid
L	Feed-in and purchased electricity meter
M	Energy Meter
a	DC
b	AC
c	Speedwire
d	Internet connection

SMA Flexible Storage System with Sunny Home Manager

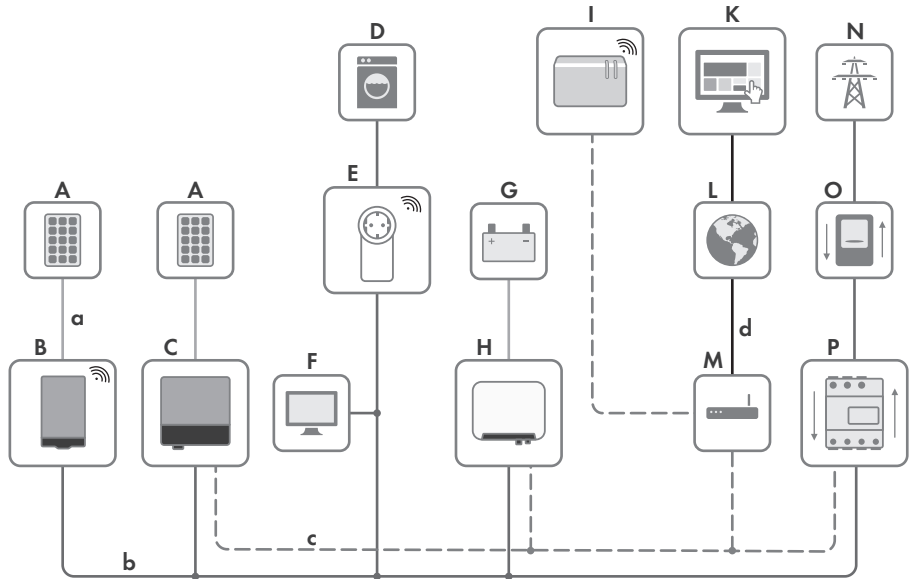

Figure 4: Overview of a SMA Flexible Storage System with Sunny Boy Storage (example)

Position	Designation
A	PV array
B	PV Inverters with BLUETOOTH (single-phase or three-phase)
C	PV inverter with SMA Speedwire/Webconnect (single-phase or three-phase)
D	Controlled load
E	Radio-controlled socket
F	Non-controllable load
G	Battery
H	Sunny Boy Storage
I	Sunny Home Manager
K	Sunny Portal
L	Internet
M	Router/network switch
N	Utility grid
O	Feed-in and purchased electricity meter

Position	Designation
P	SMA Energy Meter
a	DC
b	AC
c	Speedwire
d	Internet connection

5 Mounting

5.1 Requirements for Mounting

Requirements for the mounting location:

⚠ WARNING

Danger to life due to fire or explosion

Despite careful construction, electrical devices can cause fires.

- Do not mount the product in areas containing highly flammable materials or gases.
- Do not mount the product in potentially explosive atmospheres.

- Do not mount the inverter on a pillar.
- The mounting location must be suitable for the weight and dimensions of the inverter (see Section 15 "Technical Data", page 102).
- The mounting location must not be exposed to direct solar irradiation. Direct solar irradiation can result in the premature aging of the exterior plastic parts of the inverter and direct solar irradiation can cause the inverter to overheat. When becoming too hot, the inverter reduces its power output to avoid overheating.
- The mounting location should be freely and safely accessible at all times without the need for any auxiliary equipment (such as scaffolding or lifting platforms). Non-fulfillment of these criteria may restrict servicing.
- To ensure optimum operation, the ambient temperature should be between -20°C and $+40^{\circ}\text{C}$.
- Climatic conditions must be met (see Section 15 "Technical Data", page 102).

Permitted and prohibited mounting positions:

- The inverter must only be mounted in one of the permitted positions. This will ensure that no moisture can penetrate the inverter.
- The inverter should be mounted in such a way that the LED signals can be read without difficulty.

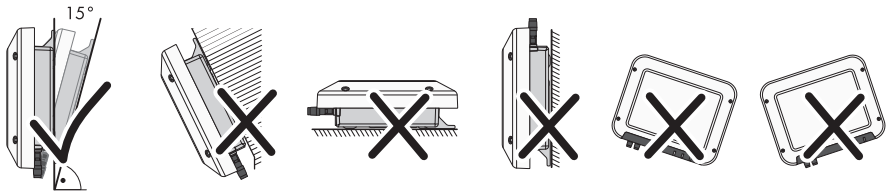

Figure 5: Permitted and prohibited mounting positions

Dimensions for mounting:

Figure 6: Position of the anchoring points (dimensions in mm (in))

Recommended clearances:

If you maintain the recommended clearances, adequate heat dissipation will be ensured. Thus, you will prevent power reduction due to excessive temperature.

- Maintain the recommended clearances to walls as well as to other inverters or objects.
- If multiple inverters are mounted in areas with high ambient temperatures, increase the clearances between the inverters and ensure sufficient fresh-air supply.

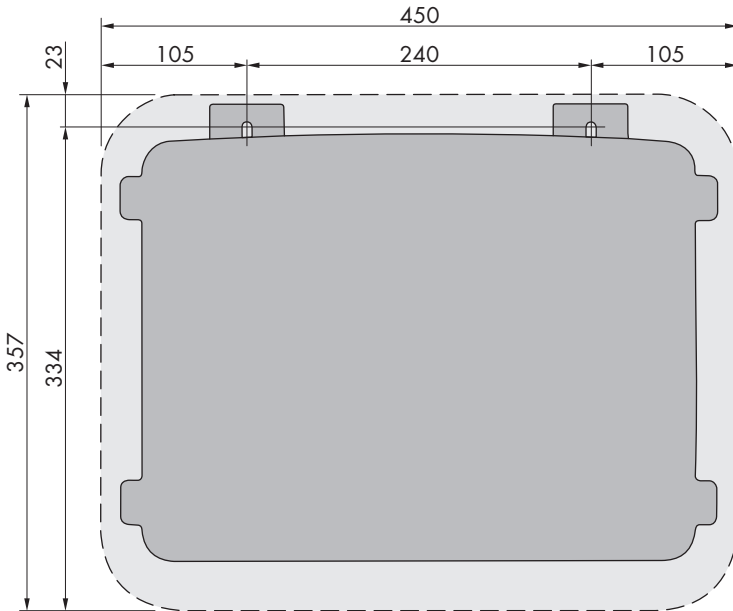
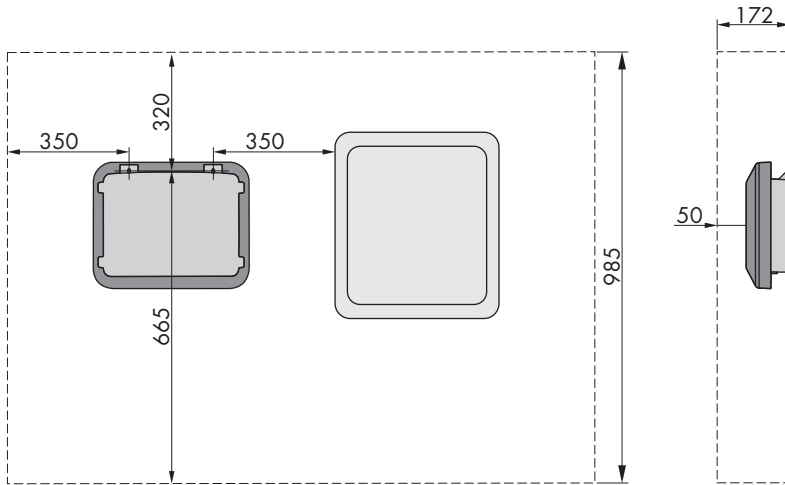

Figure 7: Recommended clearances (dimensions in mm (in))

5.2 Mounting the Inverter

⚠ QUALIFIED PERSON

Additionally required mounting material (not included in the scope of delivery):

- Two stainless steel hexagon head wood screws (AF 10, diameter 6 mm), screw length must be suitable for the support surface and the weight of the inverter (fastening bracket thickness: 4 mm)
- If necessary, two screw anchors suitable for the support surface and the screws

⚠ CAUTION

Risk of injury when lifting the inverter, or if it is dropped

The inverter weighs 9 kg. There is risk of injury if the inverter is lifted incorrectly or dropped while being transported or when attaching it to or removing it from the wall mounting bracket.

- Transport and lift the inverter carefully.

Procedure:

1. **⚠ CAUTION**

Risk of injury due to damaged cables

There may be power cables or other supply lines (e.g. gas or water) routed in the wall.

- Ensure that no lines are laid in the wall which could be damaged when drilling holes.

2. Mark the position of the drill holes. Align the markings horizontally.

3. Drill the holes.

4. Insert screw anchors into the drill holes if the support surface requires them.
5. When screwing the screws in, make sure that there is at least 6 mm left between the screw head and the support surface.
6. Hang the inverter onto the screws using the metal brackets.

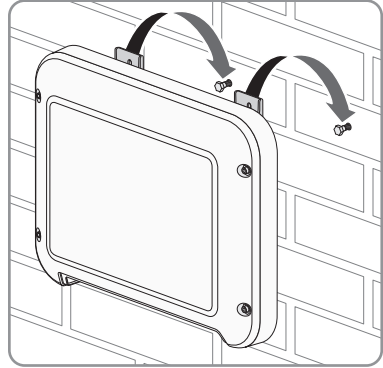

7. Tighten the screws hand-tight using a ratchet or box wrench. When doing this you can compensate for any misalignment of the drill holes by aligning the metal brackets accordingly.

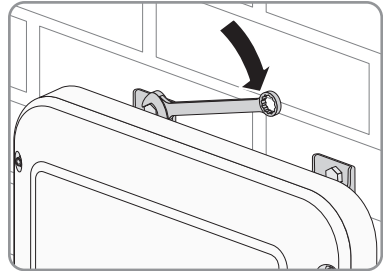

8. Ensure that the inverter is securely in place.

9.

NOTICE**Damage to the inverter due to moisture ingress**

If the electrical connection is not made immediately after the installation, the inverter is not sealed and moisture can penetrate the inverter. The inverter is only sealed if the DC connectors are connected to the inverter with the DC conductors or with sealing plugs.

If the electrical connection is to be carried out at a later time, close the DC inputs on the inverter with DC connectors and sealing plugs as described below.

- Do not insert the sealing plugs directly into the DC inputs on the inverter.
- For unused DC connectors, push down the clamping bracket and push the swivel nut up to the thread.
- Insert the sealing plug into the DC connector.

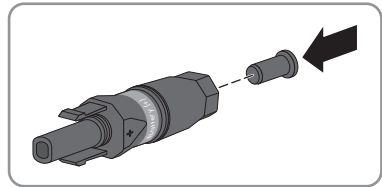

- Insert the DC connectors with sealing plugs into the corresponding DC inputs on the inverter.

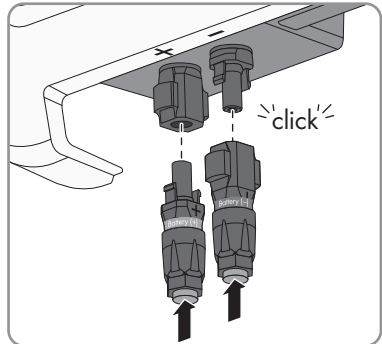

- The DC connectors snap into place.
- Ensure that the DC connectors with sealing plugs are securely in place.

6 Electrical Connection

6.1 Overview of the Connection Area

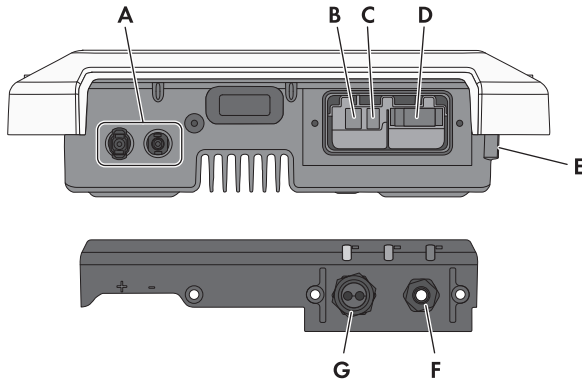

Figure 8: Connection areas at the bottom of the inverter and cable glands at the connection cap

Position	Designation
A	DC connectors for connecting the battery power cable
B	Pin connector for connecting the network cable
C	Pin connector for connecting the data cable of the battery.
D	Jack for the AC connection
E	Connection point for an additional grounding
F	Cable gland for the AC connection
G	Cable gland with cable support sleeve for connecting the network cable and the battery communication cable

6.2 AC Connection

6.2.1 Requirements for the AC Connection

Cable requirements:

- External diameter: 5 mm to 13 mm
- Conductor cross-section: 1.5 mm² to 4 mm²
- Insulation stripping length: 15 mm
- Sheath stripping length: 70 mm

- The cable must be dimensioned in accordance with the local and national directives for the dimensioning of cables. The requirements for the minimum wire size derive from these directives. Examples of factors influencing cable dimensioning are: nominal AC current, type of cable, routing method, cable bundling, ambient temperature and maximum desired line losses (for calculation of line losses, see the design software "Sunny Design" from software version 2.0 at www.SMA-Solar.com).

Load-break switch and cable protection:

NOTICE

Damage to the inverter due to the use of screw-type fuses as load-break switches

Screw-type fuses (e.g. DIAZED fuse or NEOZED fuse) are not load-break switches.

- Do not use screw-type fuses as load-break switches.
- Use a load-break switch or circuit breaker as a load disconnection unit (for information and design examples, see the Technical Information "Circuit Breaker" at www.SMA-Solar.com).

- In PV systems with multiple inverters, protect each inverter with a separate circuit breaker. Make sure to observe the maximum permissible fuse protection (see Section 15 "Technical Data", page 102). This will prevent residual voltage being present at the corresponding cable after disconnection.
- Loads installed between the inverter and the circuit breaker must be fused separately.

Residual-current monitoring unit:

- If an external residual-current device is required, install a residual-current device which trips at a residual current of 100 mA or higher (for details on selecting a residual-current device, see the Technical Information "Criteria for Selecting a Residual-Current Device" at www.SMA-Solar.com).

Overvoltage category:

The inverter can be used in grids of overvoltage category III or lower in accordance with IEC 60664-1. That means that the inverter can be permanently connected to the grid-connection point of a building. In case of installations with long outdoor cabling routes, additional measures to reduce overvoltage category IV to overvoltage category III are required (see the Technical Information "Overvoltage Protection" at www.SMA-Solar.com).

Grounding conductor monitoring:

The inverter is equipped with a grounding conductor monitoring device. This grounding conductor monitoring device detects when there is no grounding conductor connected and disconnects the inverter from the utility grid if this is the case. Depending on the installation site and grid configuration, it may be advisable to deactivate the grounding conductor monitoring. This is necessary, for example, in an IT system if there is no neutral conductor present and you intend to install the inverter between two line conductors. If you are uncertain about this, contact your grid operator or SMA Solar Technology AG.

- Grounding conductor monitoring must be deactivated after initial start-up depending on the grid configuration (see Section 9.11, page 65).

i Safety in accordance with IEC 62109 when the grounding conductor monitoring is deactivated

In order to guarantee safety in accordance with IEC 62109 when the grounding conductor monitoring is deactivated, you have to connect additional grounding:

- In order to guarantee safety in accordance with IEC 62109 when the grounding conductor monitoring is deactivated, you have to connect additional grounding (see Section 6.2.3, page 30): The additional grounding conductor must have the same cross-section as the connected grounding conductor at the connecting terminal plate for the AC cable. This prevents touch current if the grounding conductor at the connecting terminal plate for the AC cable fails.

i Connection of additional grounding

In some countries, additional grounding is generally required. In each case, observe the locally applicable regulations.

- If additional grounding is required, connect an additional grounding that has at least the same cross-section as the connected grounding conductor to the connecting terminal plate for the AC cable (see Section 6.2.3, page 30). This prevents touch current if the grounding conductor at the connecting terminal plate for the AC cable fails.

6.2.2 Connecting the Inverter to the Utility Grid

⚠ QUALIFIED PERSON

Requirements:

- Only the connecting terminal plate supplied may be used for the AC connection.
- The connection requirements of the grid operator must be met.
- The grid voltage must be in the permissible range. The exact operating range of the inverter is specified in the operating parameters.

Procedure:

1. Disconnect the AC circuit breaker and secure it against reconnection.
2. Unscrew the swivel nut from the cable gland for the AC connection at the connector cap.

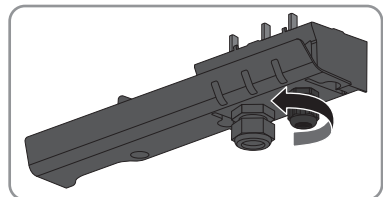

3. Thread the swivel nut over the AC cable.

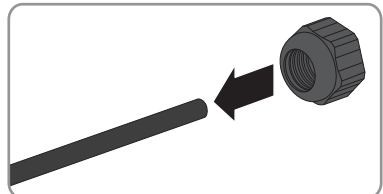

4. Thread the AC cable through the cable gland of the AC connection:

- If the external diameter of the cable is 5 mm to 7 mm, thread the AC cable through the cable gland directly.
- If the external diameter of the AC cable is 8 mm to 13 mm, first remove the inner sealing ring from the cable gland and then thread the AC cable through the cable gland. When doing so, ensure that the outer sealing ring is positioned correctly in the cable gland.

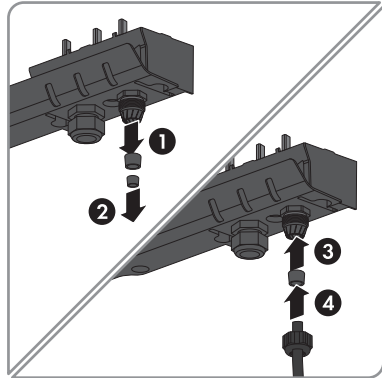
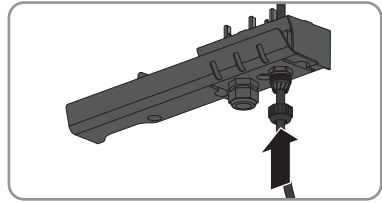

5. Dismantle 70 mm of the AC cable.

6. Shorten L and N by 5 mm each. Thus, the grounding conductor will be released from the connecting terminal plate last when tensile load is applied.

7. Strip 15 mm of the insulation of L, N and the grounding conductor.

8. Connect L, N and the grounding conductor to the connecting terminal plate for the AC connection in accordance with the labeling. When doing so, ensure that the conductors are plugged completely into the terminals up to the insulation.

Useful hint: To release the conductors from the terminals, the terminals must be opened. To do this, stick a flat-blade screwdriver (blade width: 3 mm) as far as it can go into the rectangular opening behind the terminal.

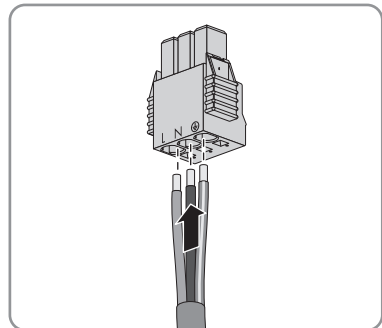

9. Ensure that all terminals are allocated to the correct conductors.

10. Make sure that all conductors are securely in place.

11. Plug the connecting terminal plate with the connected conductors for the AC connection into the slot in the inverter until the connecting terminal plate clicks into place.

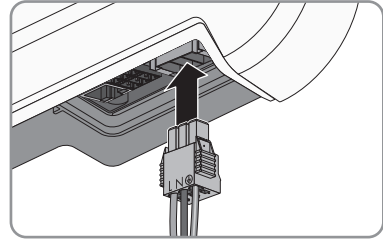

12. Ensure that the connecting terminal plate is securely in place by slightly pulling it.

6.2.3 Connecting Additional Grounding

⚠ QUALIFIED PERSON

If additional grounding or equipotential bonding is required locally, you can connect additional grounding to the inverter. This prevents touch current if the grounding conductor at the terminal for the AC cable fails.

The required clamping bracket, the cylindrical screw M5x16, the washer and the spring lock washer are part of the scope of delivery of the inverter.

i Grounding of the battery

The battery must not be grounded via the inverter.

- Do not connect the grounding of the battery to the connection point for additional grounding on the inverter.
- Ground the battery according to the battery manufacturer's specifications.

Cable requirements:

i Use of fine-stranded conductors

You can use an inflexible or a flexible, fine-stranded conductor.

- When using a fine-stranded conductor, it has to be double crimped by a ring terminal lug. Make sure that no insulated conductor is visible when pulling or bending. This will ensure sufficient strain relief by means of the ring terminal lug.

Grounding cable cross-section: max. 10 mm²

Procedure:

1. Strip off 12 mm of the grounding cable insulation.
2. Insert the screw through the spring lock washer, the clamping bracket and the washer.
3. Lightly screw the screw into the thread of the connection point for the additional grounding.

4. Lead the grounding cable between the washer and clamping bracket and tighten the screw (torque: 6 Nm) using a Torx screwdriver (TX 25).

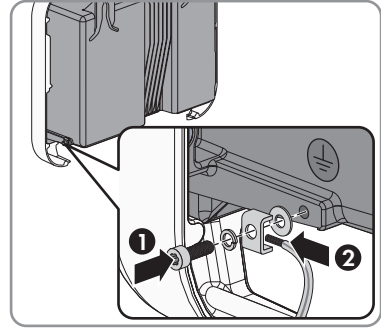

6.3 DC Connection

6.3.1 Assembling the DC Connectors

⚠ QUALIFIED PERSON

The battery connection cables must be fitted with the supplied DC connectors. Assemble the DC connectors as described in the following. Be sure to observe the correct polarity. The DC connectors are marked with the symbols "Battery (+)" and "Battery (-)".

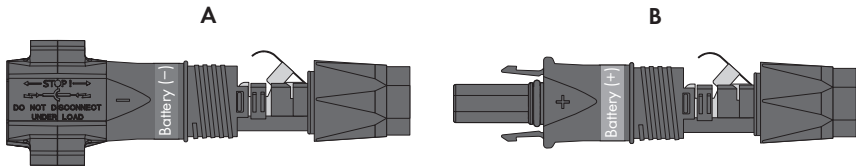

Figure 9: Negative (A) and positive (B) DC connectors

Cable requirements:

- Cable type: PV1-F, UL-ZKLA, USE2
- External diameter: 5 mm to 8 mm
- Conductor cross-section: 2.5 mm² to 6 mm²
- Qty single wires: minimum 7
- Nominal voltage: minimum 1000 V
- Using bootlace ferrules is not allowed.

⚠ DANGER**Danger to life from electric shock due to live DC cables at the battery.**

The DC cables connected to a battery are live. Touching the DC conductors or the live components leads to lethal electric shocks.

- Ensure that the inverter is disconnected from all voltage sources.
- Do not touch non-insulated cable ends.
- Do not touch the DC conductors.

Procedure:

1. Strip 12 mm of the cable insulation.
2. Insert the stripped cable into the DC connector up to the stop. When doing so, ensure that the stripped cable and the DC connector are of the same polarity.
3. Press the clamping bracket down until it audibly snaps into place.

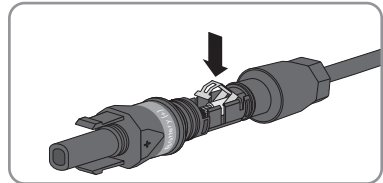
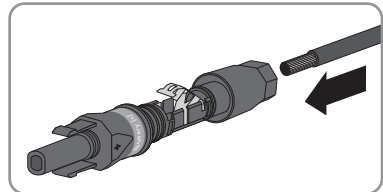

- ☑ The stranded wire can be seen inside the clamping bracket chamber.

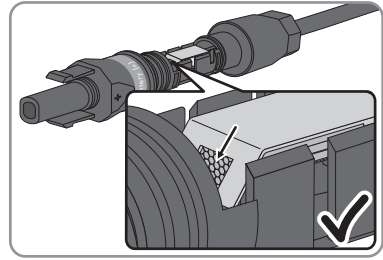

- ✘ The stranded wire cannot be seen in the chamber?

The cable is not correctly in place.

- Release the clamping bracket. To do so, insert a screwdriver (blade width: 3.5 mm) into the clamping bracket and pry the clamping bracket open.

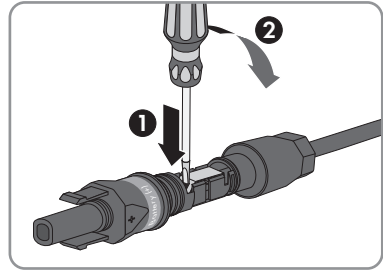

- Remove the cable and go back to step 2.

4. Push the swivel nut up to the thread and tighten (torque: 2 Nm).

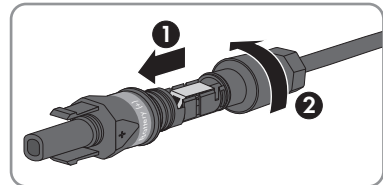

6.3.2 Connecting the Power Cable of the Battery

⚠ QUALIFIED PERSON

NOTICE

Damage to the DC connectors due to the use of contact cleaner of other cleaning agents

Some contact cleaners or other cleaning agents may contain substances that decompose the plastic of the DC connectors.

- Do not use contact cleaners or other cleaning agents for cleaning the DC connectors.

⚠ DANGER

Danger to life from electric shock due to live DC cables when connecting an PV array

If the DC connectors with the DC cables of the PV array were accidentally connected to the inverter, the high voltages of the PV array are present at the DC conductors. Pulling the DC connectors under load can cause an electric arc to occur leading to electric shock and burns. Correcting the connection immediately poses a danger to life.

- It is imperative that the DC connectors are not disassembled during the day.
- Stop working on the inverter and wait until dark.
- If you would like to leave the PV system to continue work when it is dark, set up protection against contact (e.g. a fence).
- Disassemble and then assemble the DC connectors again only once it is dark.

Requirements:

- Only the supplied connectors for connecting the battery power cable may be used.
- The length of the battery power cable must not exceed 10 m.

Procedure:

1. Ensure that the DC connectors have the correct polarity.

If the DC connector is equipped with a DC cable of the wrong polarity, the DC connector must be reassembled. The DC cable must always have the same polarity as the DC connector.

2. Connect the assembled DC connectors to the inverter.

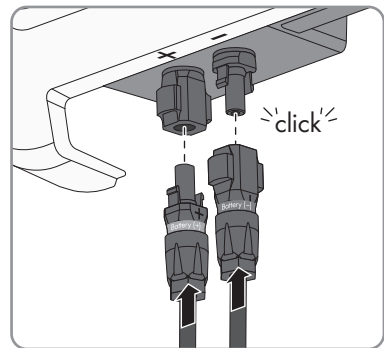

- The DC connectors snap into place.

3. Ensure that all DC connectors are securely in place.

6.3.3 Disassembling the DC Connectors

⚠ QUALIFIED PERSON

To disassemble the DC connectors (e.g. due to faulty assembly), proceed as follows.

⚠ DANGER

Danger to life from electric shock due to live DC cables at the battery.

The DC cables connected to a battery are live. Touching the DC conductors or the live components leads to lethal electric shocks.

- Ensure that the inverter is disconnected from all voltage sources.
- Do not touch non-insulated cable ends.
- Do not touch the DC conductors.

⚠ DANGER

Danger to life from electric shock due to live DC cables when connecting an PV array

If the DC connectors with the DC cables of the PV array were accidentally connected to the inverter, the high voltages of the PV array are present at the DC conductors. Pulling the DC connectors under load can cause an electric arc to occur leading to electric shock and burns. Correcting the connection immediately poses a danger to life.

- It is imperative that the DC connectors are not disassembled during the day.
- Stop working on the inverter and wait until dark.
- If you would like to leave the PV system to continue work when it is dark, set up protection against contact (e.g. a fence).
- Disassemble and then assemble the DC connectors again only once it is dark.

Procedure:

1. Release and remove all DC connectors. To do this, insert a flat-blade screwdriver or an angled screwdriver (blade width 3.5 mm) into one of the slide slots and pull the DC connectors out in a downward direction. Do not pull on the cable.

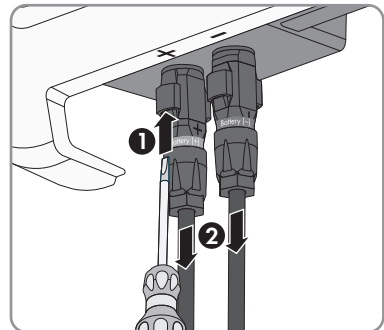

2. Remove the DC connector swivel nut.

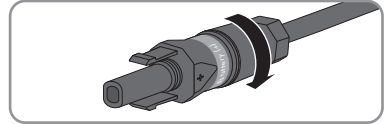

3. Unlock the DC connector. To do this, insert a flat-blade screwdriver (blade width: 3.5 mm) into the side catch mechanism and pry the catch mechanism open.

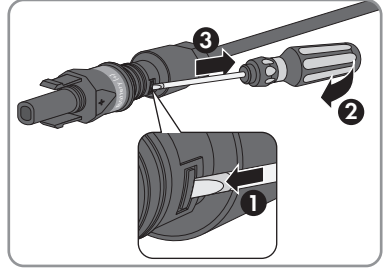

4. Carefully pull the DC connector apart.

5. Release the clamping bracket. To do so, insert a flat-blade screwdriver (blade width: 3.5 mm) into the clamping bracket and pry the clamping bracket open.

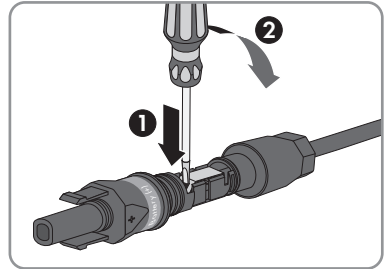

6. Remove the cable.

6.4 Connecting the Network and Energy Meter

⚠ QUALIFIED PERSON

⚠ DANGER

Danger to life due to electric shock

Overvoltages (e. g. in the case of a flash of lightning) can be further conducted into the building and to other connected devices in the same network via network cables or other data cables if there is no overvoltage protection.

- Ensure that all devices in the same network and the battery are integrated in the existing overvoltage protection.
- When laying the network cables or other data cables outdoors, attention must be given to suitable overvoltage protection at the cable transition from the inverter or the battery outdoors to the inside of a building.

i Failure-free operation of all system components due to tethered connection

- To ensure failure-free operation, SMA Solar Technology AG recommends connecting all system components with each other via Speedwire.

Connection variant: Flexible Storage System without Sunny Home Manager

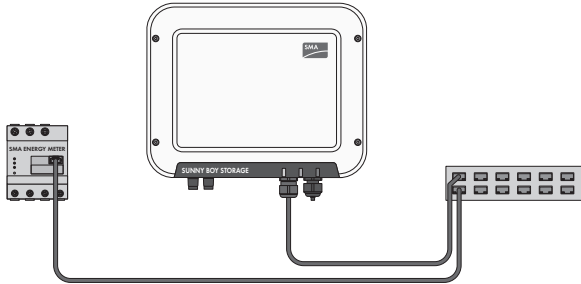

Figure 10: Network connection in the SMA Flexible Storage System without Sunny Home Manager (example)

Connection variant: Flexible Storage System with Sunny Home Manager

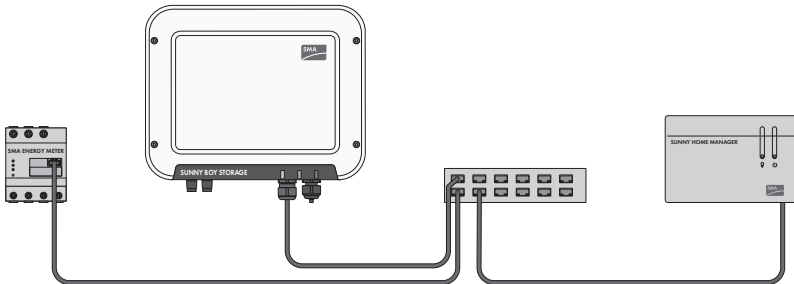

Figure 11: Network connection in the SMA Flexible Storage System With Sunny Home Manager (example)

Router requirements:

- The router should support DHCP.
- SMA Solar Technology AG recommends installing routers or network switches with a data transfer rate of 100 Mbit/s. The inverter supports routers and network switches with a data transfer rate of 10 Mbit/s and 100 Mbit/s.
- The routers and network switches with router function must forward the Multicast telegrams (telegrams with destination address 239.0.0.0 to 239.255.255.255) required for the network connection to all nodes of the network.
- If copper cabling is used for the transfer of data, the cable route between inverter and router may not exceed 100 m.

Additionally required material (not included in the scope of delivery):

- One network cable for the direct connection with the Energy Meter or for the connection with the local network (e.g. via a router)
- Where required: Field-assembly RJ45 connector for the network cable. SMA Solar Technology AG recommends the connector "MFP8 T568 A Cat.6A" from "Telegärtner".

Cable requirements:

The cable length and quality affect the quality of the signal. Observe the following cable requirements.

- Cable type: 100BaseTx
- Cable category: Cat5, Cat5e, Cat6, Cat6a or Cat7
- Plug type: RJ45 of Cat5, Cat5e, Cat6 or Cat6a
- Shielding: SF/UTP, S/UTP, SF/FTP or S/FTP
- Number of insulated conductor pairs and insulated conductor cross-section: at least $2 \times 2 \times 0.22 \text{ mm}^2$
- Maximum cable length between two nodes when using patch cables: 50 m
- Maximum cable length between two nodes with installation cable: 100 m
- UV-resistant for outdoor use

Procedure:

1. When using a self-assembly network cable, assemble the RJ45 connector and connect to the network cable (see connector documentation).
2. Unscrew the swivel nut from the cable gland for the connection of a network cable and the battery communication cable at the connection cap.
3. Thread the swivel nut over the network cable.
4. Press the cable support sleeve out of the cable gland.
5. Remove the filler plug from the cable support sleeve.
6. Route the network cable through an opening in the cable support sleeve.

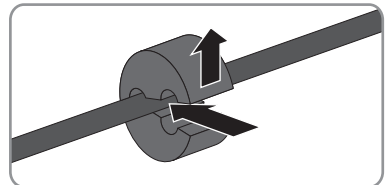

7. Thread the network cable through the cable gland.

8. Insert the RJ45 plug of the network cable into the network pin connector on the inverter until it snaps into place.

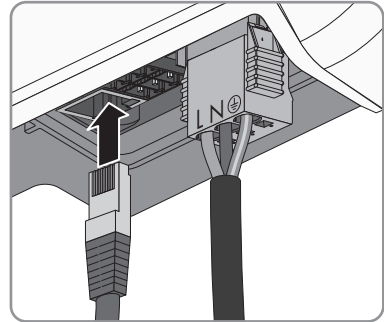

9. Ensure that the network connector is securely in place by pulling slightly on the network cable.
10. Connect the other end of the network cable to the local network (e.g. via a router). You can only connect the inverter to other nodes via star topology.
11. Connecting the data cable of the battery (see Section 6.5, page 39).

6.5 Connecting the Data Cable of the Battery

⚠ QUALIFIED PERSON

⚠ DANGER

Danger to life due to electric shock

Overvoltages (e. g. in the case of a flash of lightning) can be further conducted into the building and to other connected devices in the same network via network cables or other data cables if there is no overvoltage protection.

- Ensure that all devices in the same network and the battery are integrated in the existing overvoltage protection.
- When laying the network cables or other data cables outdoors, attention must be given to suitable overvoltage protection at the cable transition from the inverter or the battery outdoors to the inside of a building.

i Communication between Inverter and Battery

- Communication between the inverter and the battery takes place via the battery communication cable via CAN bus.

Additionally required material (not included in the scope of delivery):

- One battery communication cable for the communication between inverter and battery

Cable requirements:

- Cable type: Twisted Pair
- Shielding: yes
- Conductor cross-section: 0.25 mm² to 0.34 mm²
- Number of conductor pairs: 4

- Maximum cable length: 10 m
- UV-resistant for outdoor use. SMA Solar Technology AG recommends the cable "UC900 SS23 Cat.7 PE"
- Comply with the requirements of the battery manufacturer.

Plug assignment:

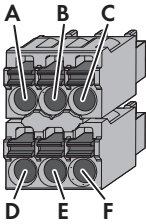
Plug	Position	Assignment
	A	Not assigned
	B	Enable
	C	GND and shielding
	D	CAN L
	E	CAN H
	F	+12V

Procedure:

1. Thread the swivel nut over the data cable of the battery.
2. Route the data cable of the battery through an opening in the cable support sleeve.

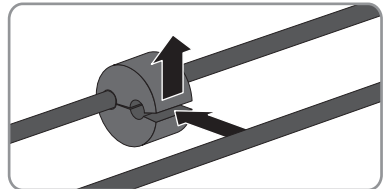

3. Insert the data cable of the battery through the cable gland.
4. Dismantle the data cable of the battery.
5. Cut off an entire pair of conductors and an insulated conductor. Make sure that **CAN L** and **CAN H** as well as **+12V** and **GND** each consist of a pair of conductors.

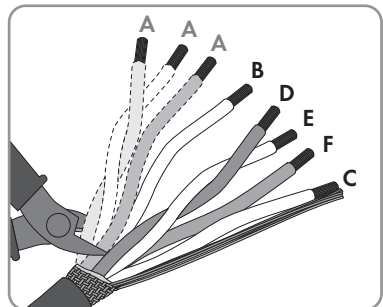

Conductor	Assignment
A	Not assigned
B	Enable

Conductor	Assignment
C	GND and shielding
D	CAN L
E	CAN H
F	+12V

- Strip the insulation off the wires.
- Combine the shielding and insert it into a bootlace ferrule (1.5 mm² without collar) together with **GND** and crimp using a crimping tool.

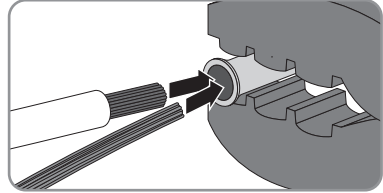

- Connect the shielding and **GND** with the bootlace ferrule to the **GND** terminal of the plug for the battery communication connection. Observe the plug assignment.

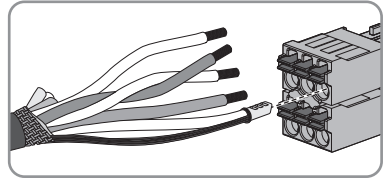

- Connect the remaining conductors of the battery communication cable to the plug for the battery communication connection. Pay attention to the plug assignment and make sure that **CAN L** and **CAN H** as well as **+12V** and **GND** each consist of a pair of conductors.

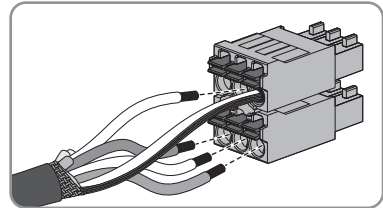

- Make sure that the conductors are plugged into the plug tightly by pulling slightly on the conductors.
- Insert the plug for the battery communication connection into the pin connector on the right of the network jack. The terminals must face forward and the terminals for releasing the conductors must face to the rear towards the mounting surface.

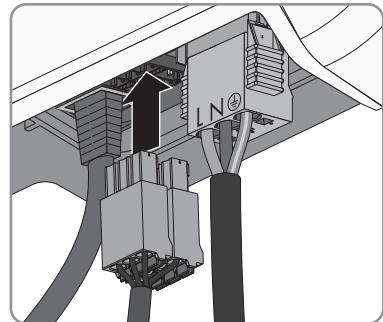

- Make sure that the plug for the battery communication cable is plugged in tightly.

13. Press the cable support sleeve into the cable gland.

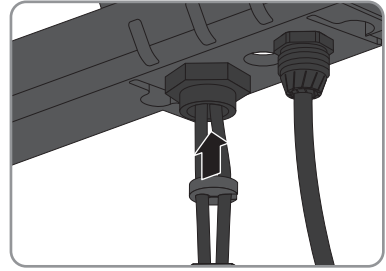

14. Screw the swivel nut hand-tight onto the cable gland for the connection of the network cable and the battery communication cable.
15. Tighten the connection cap to the inverter using the three screws and a Torx screwdriver (TX20) (torque: 3.5 Nm).

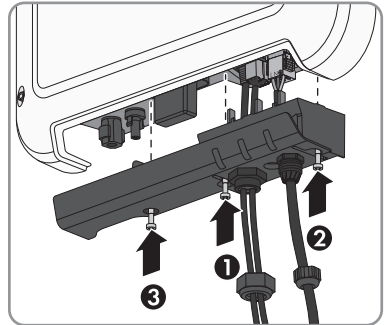

16. Screw the swivel nuts onto the cable glands on the connection cap.

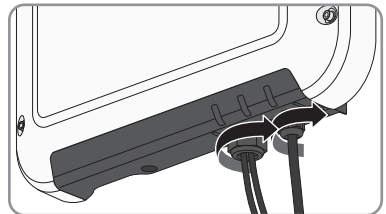

17. Connect the other end of the battery communication cable directly to the battery (see the battery manufacturer's manual).

7 Commissioning

7.1 Commissioning Procedure

QUALIFIED PERSON

This section describes the commissioning procedure and gives an overview of the steps you must perform in the prescribed order.

Procedure	See
1. Commission the inverter.	Section 7.2, page 43
2. Establish a connection to the user interface of the inverter. There are three connection options available to choose from: <ul style="list-style-type: none"> • Direct connection via WLAN • Direct connection via Ethernet • Connection via Ethernet in the local network 	Section 8.1, page 48
3. Log into the user interface.	Section 8.2, page 51
4. Select the inverter configuration option. Please note that the personal SMA Grid Guard code for changing the grid-relevant parameters must be available after completion of the first ten feed-in hours or installation assistant (see "Application for the SMA Grid Guard code" available at www.SMA-Solar.com).	Section 7.3, page 44
5. Ensure that the country data set has been configured correctly.	Section 9.3, page 60
6. For PV systems in Italy: Start the self-test.	Section 7.4, page 47
7. Make further inverter settings as needed.	Section 9, page 58

7.2 Commissioning the Inverter

QUALIFIED PERSON

Requirements:

- The AC circuit breaker must be correctly rated and mounted.
- The inverter must be correctly mounted.
- All cables must be correctly connected.

Procedure:

1. Switch on the AC circuit breaker.
2. Switch on the battery or the load-break switch of the battery (see documentation of the battery manufacturer).
 - ☑ All three LEDs light up briefly. The start-up phase begins.
 - ✘ The red LED is glowing?
 - An error has occurred.
 - Rectify the error (see Section 12, page 71).
3. Establish a connection to the user interface of the inverter (see Section 8.1, page 48).

7.3 Selecting a configuration option

⚠ QUALIFIED PERSON

After you have logged onto the user interface as **Installer**, the **Configuring the Inverter** page opens.

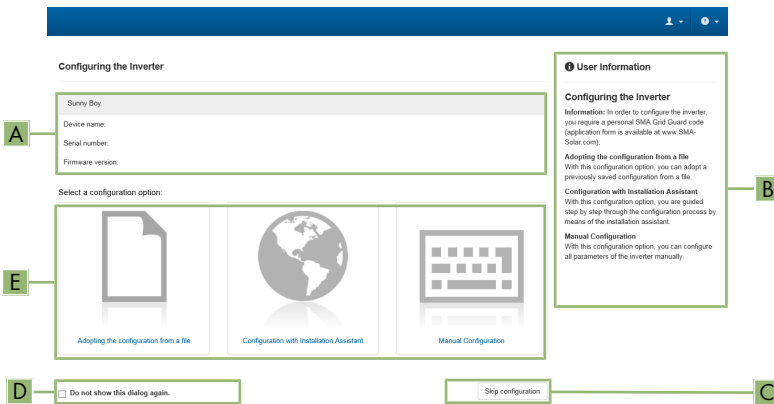

Figure 12: Layout of the **Configuring the Inverter** page

Position	Designation	Description
A	Device information	Provides the following information: <ul style="list-style-type: none"> • Device name • Inverter serial number • Inverter firmware version
B	User information	Provides brief information on the listed configuration options

Position	Designation	Description
C	Skip configuration	Offers the option of skipping the inverter configuration and going directly to the user interface (not recommended; the inverter cannot be operated without configuration)
D	Checkbox	Allows you to choose not to have the displayed page displayed again when the user interface is called up again
E	Configuration options	Provides a selection of the various configuration options

Procedure:

On the **Configuring the Inverter** page, three configuration options are available to choose from. Select one of the three options and proceed for the selected option as described below. SMA Solar Technology AG recommends carrying out the configuration with the Installation Assistant. This way, you ensure that all relevant parameters are set for optimal inverter operation.

- Adoption of configuration from a file
- Configuration with the Installation Assistant (Recommended)
- Manual configuration

Adoption of configuration from a file

You can adopt the inverter configuration from a file. To do this, there must be an inverter configuration saved to a file.

Procedure:

1. Select the configuration option **Adopting configuration from a file**.
2. Select [**Browse...**] and select the desired file.
3. Select [**Import file**].

Configuration with the installation assistant (recommended)

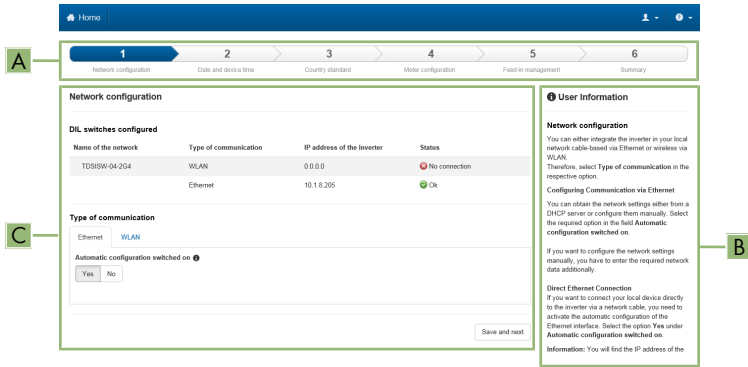

Figure 13: Layout of the installation assistant

Position	Designation	Description
A	Configuration steps	Overview of the installation assistant steps. The number of steps depends on the type of device and the additionally installed modules. The current step is highlighted in blue.
B	User information	Information about the current configuration step and the setting options of the configuration step.
C	Configuration field	You can make settings in this field.

Procedure:

1. Select the configuration option **Configuration with Installation Assistant**.
 - The Installation Assistant will open.
2. Follow the Installation Assistant steps and make the settings appropriate for your system.
3. For every setting made in a step, select [**Save and next**].
 - In the last step, all made settings are listed in a summary.
4. To save the settings to a file, select [**Export a summary**] and save the file on your computer, tablet PC or smartphone.
5. To correct settings you made, select [**Back**], navigate to the desired step, correct settings and select [**Save and continue**].
6. Once all settings are correct, select [**Next**] in the summary.
 - The start page of the user interface opens.

Manual configuration

You can configure the inverter manually by setting the desired parameters.

Procedure:

1. Select the configuration option **Manual Configuration**.
 - The **Device Parameters** menu on the user interface will open and all available parameter groups of the inverter will be displayed.
2. Select [**Edit parameters**].
3. Select the desired parameter group.
 - All available parameters of the parameter group will be displayed.
4. Set the desired parameters.
5. Select [**Save all**].
 - The inverter parameters are set.

7.4 Starting the Self-Test (For Italy Only)

QUALIFIED PERSON

The self-test is only required for inverters to be commissioned in Italy. The Italian standard requires that all inverters feeding into the utility grid are equipped with a self-test function in accordance with CEI 0-21. During the self-test, the inverter will consecutively check the reaction times for overvoltage, undervoltage, maximum frequency and minimum frequency.

The self-test changes the upper and lower disconnection values for each protective function on a linear basis for frequency monitoring and voltage monitoring. As soon as the measured value exceeds the permitted disconnection threshold, the inverter disconnects from the utility grid. In this way, the inverter determines the reaction time and checks itself.

After the self-test has been completed, the inverter automatically switches back to feed-in operation, resets the original disconnection conditions and connects to the utility grid. The test takes approximately three minutes.

Requirements:

- The country data set of the inverter must be set to **CEI 0-21 internal**.

Procedure:

1. Select the menu **Device Configuration**.
2. Select [**Settings**].
3. Select [**Starting the Self-Test**] in the subsequent context menu.
4. Observe the instructions shown in the dialog and save the report of the self-test, if necessary.

8 Using the Inverter User Interface

8.1 Establishing a connection to the user interface

8.1.1 Establishing a direct connection via WLAN

Requirements:

- The inverter must be commissioned.
- A computer, tablet PC or smartphone with WLAN interface must be available.
- In the case of a computer connection, one of the following web browsers must be installed: Firefox (as of version 25), Internet Explorer (as of version 10), Safari (as of version 7), Opera (as of version 17) or Google Chrome (as of version 30).
- In the case of a tablet PC or smartphone connection, one of the following web browsers must be installed: Firefox (as of version 25), Safari (as of version iOS 7) or Google Chrome (as of version 29).
- The personal SMA Grid Guard code of the Installer must be available for the changing of grid-relevant settings after completion of the first ten operating hours (see "Application for SMA Grid Guard Code" at www.SMA-Solar.com).

i Inverter SSID and IP address and necessary passwords

- Inverter SSID in WLAN: SMA[serial number] (e.g. SMA2130019815)
- Standard WLAN password (usable for initial configuration to completion of the first ten operating hours): SMA 12345
- Device-specific WLAN password (usable for initial configuration to completion of the first ten operating hours): see WPA2-PSK on the type label of the inverter or on the back of the manual included in the delivery
- Standard IP inverter address for a direct connection via WLAN outside of a local network: 192.168.12.3

i Importing and exporting files with end devices having an iOS operating system is not possible.

For technical reasons, importing and exporting files (e.g. importing an inverter configuration, saving the current inverter configuration or exporting events) is not possible with mobile end devices having an iOS operating system.

- Use an end device that does not have an iOS operating system for importing and exporting files.

The procedure can be different depending on the terminal devices used (e.g. computer, tablet PC or smartphone). If the procedure described does not apply to your device, establish the direct connection via WLAN as described in the manual of your device.

Procedure:

1. If your computer, tablet PC or smartphone has a WPS function:
 - Activate the WPS function on the inverter. To do this, tap on the enclosure lid of the inverter twice.
 - The blue LED flashes quickly for approx. two minutes. The WPS function is active.
 - Activate the WPS on your device.
 - The connection with your device will be established automatically. It can take up to 20 seconds for this connection to be established.
2. If your computer, tablet PC or smartphone does not have a WPS function:
 - Search for WLAN networks with your device.
 - Select the SSID of the inverter **SMA[serial number]** in the list with the found WLAN networks.
 - Enter the inverter WLAN password. Within the first 10 operating hours, you must use the standard WLAN password **SMA12345**. After the first 10 operating hours, you must use the device-specific WLAN password (WPA2-PSK) of the inverter. The WLAN password (WPA2-PSK) is printed on the type label.
3. Enter the IP address **192.168.12.3** or, if your device supports mDNS services, **SMA[serial number].local** in the address line of the web browser and press the enter key.
4.  **Web browser signals a security vulnerability**

After the IP address has been confirmed by pressing the enter key, a message might appear indicating that the connection to the user interface of the inverter is not secure. SMA Solar Technology AG guarantees that calling up the user interface is secure.

 - Continue loading the user interface.
 - The login page of the user interface opens.

8.1.2 Establishing a Direct Connection via Ethernet

Requirements:

- The inverter must be commissioned.
- A computer with an Ethernet interface must be available.
- The inverter must be connected directly to a computer.
- One of the following web browsers must be installed: Firefox (as of version 25), Internet Explorer (as of version 10), Safari (as of version 7), Opera (as of version 17) or Google Chrome (as of version 30).
- The personal SMA Grid Guard code of the Installer must be available for the changing of grid-relevant settings after completion of the first ten operating hours (see certificate "Application for SMA Grid Guard Code" at www.SMA-Solar.com).

 IP address of the inverter

- Standard inverter IP address for direct connection via Ethernet: 169.254.12.3

Procedure:

1. Open the web browser of your device, enter the IP address **169.254.12.3** in the address line and press the enter key.
 2.  **Web browser signals a security vulnerability**
 After the IP address has been confirmed by pressing the enter key, a message might appear indicating that the connection to the user interface of the inverter is not secure. SMA Solar Technology AG guarantees that calling up the user interface is secure.
 - Continue loading the user interface.
- The login page of the user interface opens.

8.1.3 Establishing a Connection via Ethernet in the local network

New IP address for connecting with a local network

If the inverter is connected to a local network via a network cable (e.g. via a router), the inverter will receive a new IP address. Depending on the type of configuration, the new IP address will be assigned automatically by the DHCP server (router) or manually by you. Upon completion of the configuration, the inverter is only reachable via this new IP address or the alternative addresses.

Access addresses of the inverter:

- Generally applicable access address, e.g. for android products: IP address manually assigned or assigned by the DHCP server (router) (identification via network scanner software or router manual).
- Alternative access address for Apple products: SMA[serial number].local (e.g. SMA2130019815.local)
- Alternative access address for certain Windows products: SMA[serial number] (e.g. SMA2130019815)

Requirements:

- The inverter must be connected to the local network via a network cable (e.g. via a router).
- The inverter must be integrated in the local network.
- A computer, tablet PC or smartphone must be available and the computer, tablet PC or smartphone must be connected with the network to which the inverter is also connected.
- In the case of a computer connection, one of the following web browsers must be installed: Firefox (as of version 25), Internet Explorer (as of version 10), Safari (as of version 7), Opera (as of version 17) or Google Chrome (as of version 30).
- In the case of a tablet PC or smartphone connection, one of the following web browsers must be installed: Firefox (as of version 25), Safari (as of version iOS 7) or Google Chrome (as of version 29).

- The personal SMA Grid Guard code of the Installer must be available for the changing of grid-relevant settings after completion of the first ten feed-in hours (see certificate "Application for SMA Grid Guard Code" at www.SMA-Solar.com).

Procedure:

1. Open the web browser of your device, enter the IP address of the inverter in the address line of the web browser and press the enter key.
 2.  **Web browser signals a security vulnerability**
 After the IP address has been confirmed by pressing the enter key, a message might appear indicating that the connection to the user interface of the inverter is not secure. SMA Solar Technology AG guarantees that calling up the user interface is secure.
 - Continue loading the user interface.
- The login page of the user interface opens.

8.2 Logging In and Out of the User Interface

After a connection to the user interface of the inverter has been established, the login page opens. Log onto the user interface as described below.

Usage of cookies

For the correct display of the user interface, cookies are required. The cookies are used for convenience only. By using this user interface you agree to the placement of cookies.

Log in as installer or user for the first time

Password for PV systems that are registered in a communication product

The password for the user group **Installer** is also the system password. If you assign a password for the user group **Installer** via the user interface of the inverter, the password must match the PV system password. If the new password for logging onto the user interface does not match the system password in the communication product, the inverter cannot be reached by the communication product.

- A uniform password is assigned for all Speedwire devices in the PV system.

Procedure:

1. In the drop-down list **Language**, select the desired language.
 2. In the **User group** drop-down list, select the entry **Installer** or **User**.
 3. In the **New password** field, enter a new password for the selected user group.
 4. In the **Repeat password** field, enter the new password again.
 5. Select **Login**.
- The **Configuring the Inverter** page or the user interface start page opens.

Log in as the User or Installer

1. In the drop-down list **Language**, select the desired language.
2. In the **User group** drop-down list, select the entry **Installer** or **User**.

3. Enter the password in the field **Password**.
 4. Select **Login**.
- The start page of the user interface opens.

Log Out as the User or Installer

1. On the right-hand side of the menu bar, select the menu **User Settings**.
 2. In the subsequent context menu, select [**Logout**].
- The login page of the user interface opens. The logout was successful.

8.3 Start Page Design of the User Interface

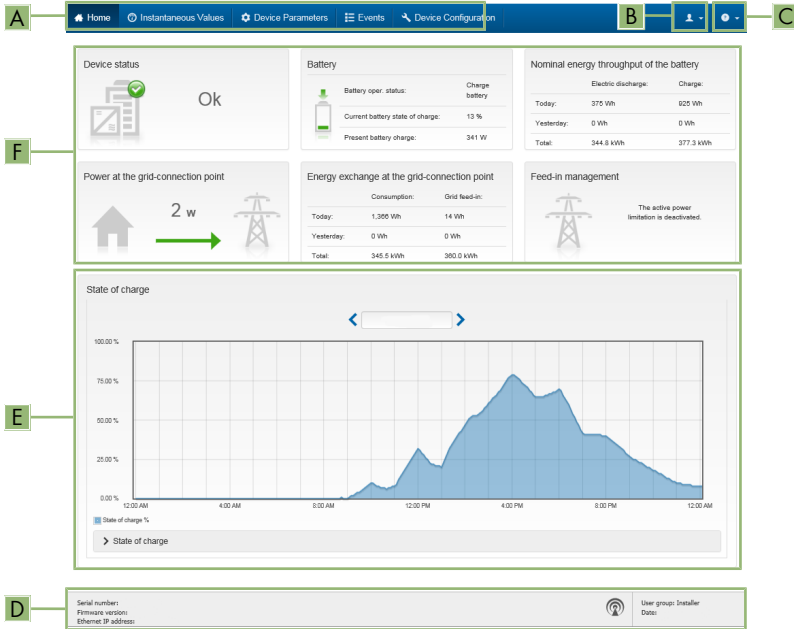

Figure 14: Start Page Design of the User Interface

Position	Designation	Description
A	Menu	<p>Provides the following functions:</p> <ul style="list-style-type: none"> • Home Opens the user interface homepage • Instantaneous values Current measured values of the inverter • Device Parameters The various operating parameters of the inverter can be viewed and configured here depending on the user group. • Events All events that have occurred in the selected time period are displayed here. The event types are Information, Warning and Error. Currently existing events of the types Error and Warning will be additionally displayed in the Device status viewlet. However, only the higher-priority event is displayed. If, for example, there is a Warning and an Error present at the same time, only the Error will be displayed. • Device configuration The following settings for the inverter can be performed here. The selection available is dependent on which user group you are logged in as and the operating system of the device with which the user interface has been called up. <ul style="list-style-type: none"> - Changing device names - Updating firmware (not available with devices having an iOS operating system) - Saving a configuration to file (not available with devices having an iOS operating system) - Loading a configuration from a file (not available with devices having an iOS operating system)
B	User settings	<p>Provides the following functions, depending on the user group logged in:</p> <ul style="list-style-type: none"> • Start the installation assistant • SMA Grid Guard login • Logout

Position	Designation	Description
C	Help	Provides the following functions: <ul style="list-style-type: none">• Displaying information on Open Source licenses used• Link to the website of SMA Solar Technology AG
D	Status bar	Displays the following information: <ul style="list-style-type: none">• Inverter serial number• Inverter firmware version• IP address of the inverter within the local network and/or IP address of the inverter during WLAN connection• User group logged in• Date and device time of the inverter

Position	Designation	Description
E	State of charge	Chronological sequence of the state of charge (SOC) of the battery
F	Status display	<p>The various areas display information on the current status of the system.</p> <ul style="list-style-type: none"> • Device status Displays whether the inverter and/or the battery is/are currently in a fault-free operating state or whether there is an event type Error or Warning present. • Feed-in management Displays whether the inverter is currently limiting its active power. • Nominal energy throughput of the battery Indicates how much energy has been charged to the battery and how much has been discharged from the battery. • Battery Displays the following information: <ul style="list-style-type: none"> - Operating status of battery - Current battery state of charge - Current battery charging power • Energy exchange at the grid-connection point Indicates how much energy was obtained from the utility grid to supply the household and how much the PV system fed in. • Power at the grid-connection point Indicates which power is currently fed in or obtained at the grid-connection point.

8.4 Changing the Password

The password for the inverter can be changed for both user groups. Furthermore, the user group **Installer** can change the password for the user group **User** as well as its own password.

PV systems registered in a communication product

With PV systems that are registered in a communication product (e.g. Sunny Portal, Sunny Home Manager), you can also assign a new password for the user group **Installer** via the communication product. The password for the user group **Installer** is also the system password. If you assign a password for the user group **Installer** via the user interface of the inverter that does not correspond to the system password in the communication product, the inverter can no longer be reached by the communication product.

- Ensure that the password for the user group **Installer** is the same as the system password in the communication product.

Procedure:

1. Activate the user interface (see Section 8.1, page 48).
2. Log into the user interface (see Section 8.2, page 51).
3. Call up the menu **Device Parameters**.
4. Select [**Edit parameters**].
5. In the parameter group **User Rights > Access Control** change the password of the desired user group.
6. Select [**Save all**] to save the changes.

9 Configuration of the Inverter

9.1 Changing Operating Parameters

The operating parameters of the inverter are set to certain values by default. You can change the operating parameters to optimize the performance of the inverter.

This section describes the basic procedure for changing operating parameters. Always change operating parameters as described in this section. Some function-sensitive parameters can only be viewed by qualified persons and can only be changed by qualified persons by entering the personal SMA Grid Guard code.

No configuration via Sunny Explorer

Sunny Explorer does not support the configuration of inverters with their own user interface. The inverter can be detected via Sunny Explorer, however it is expressly not recommended to use Sunny Explorer to configure this inverter. SMA Solar Technology AG does not accept liability for missing or incorrect data and possibly resulting yield losses.

- Use the user interface for the configuration of the inverter.

Requirements:

- The changes to the grid-relevant parameters must be approved by the grid operator.
- When changing grid-relevant parameters, the SMA Grid Guard code must be available (see "Application for SMA Grid Guard Code" at www.SMA-Solar.com).
- Modifications of factory-set parameters for the battery configuration must be approved by the battery manufacturer.

Procedure:

1. Activate the user interface (see Section 8.1, page 48).
 2. Log into the user interface (see Section 8.2, page 51).
 3. Call up the menu **Device Parameters**.
 4. Select [**Edit parameters**].
 5. Log in using the SMA Grid Guard code to change those parameters designated by a lock (only for installers):
 - Select the menu **User Settings** (see Section 8.3, page 53).
 - In the subsequent context menu, select [**SMA Grid Guard login**].
 - Enter the SMA Grid Guard code and select [**Login**].
 6. Expand the parameter group that contains the parameter which is to be configured.
 7. Change the desired parameters.
 8. Select [**Save all**] to save the changes.
- The inverter parameters are set.

i **Accepting the settings**

Saving the made settings is indicated by an hourglass symbol on the user interface. If the DC voltage is sufficient, the data is transferred directly to the inverter and accepted. If the DC voltage is too low (e.g. when the battery is switched off), the settings are saved, but they cannot be directly transferred to or accepted by the inverter. As long as the inverter has not yet received and accepted the settings, the hourglass symbol will continue to be displayed on the user interface. The settings will be accepted when there is sufficient DC voltage applied and the inverter restarts. As soon as the hourglass symbol appears on the user interface, the settings have been saved. The settings will not be lost. You can log off of the user interface and leave the system.

9.2 Starting the Installation Assistant

⚠ QUALIFIED PERSON

The installation assistant leads you step-by-step through the steps necessary for the initial configuration of the inverter.

Layout of the installation assistant

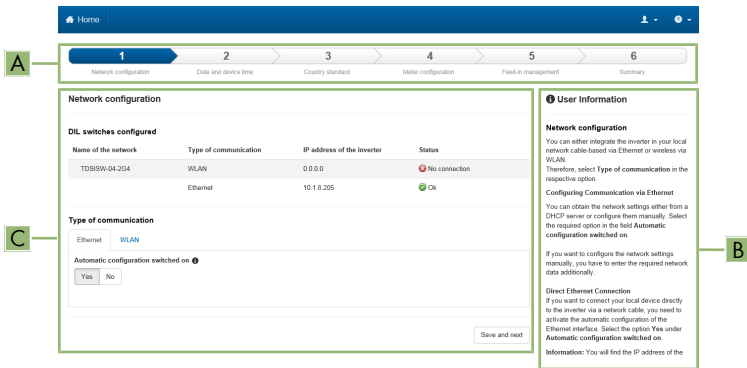

Figure 15: Layout of the installation assistant

Position	Designation	Description
A	Configuration steps	Overview of the installation assistant steps. The number of steps depends on the type of device and the additionally installed modules. The current step is highlighted in blue.
B	User information	Information about the current configuration step and the setting options of the configuration step.
C	Configuration field	You can make settings in this field.

Requirement:

- When configuring after completion of the first ten operating hours, the SMA Grid Guard code must be available (see "Application for SMA Grid Guard Code" at www.SMA-Solar.com).

Procedure:

1. Activate the user interface (see Section 8.1, page 48).
 2. Log in as **Installer**.
 3. Select the menu **User Settings** (see Section 8.3, page 53) on the start page of the user interface.
 4. In the context menu, select [**Start the installation assistant**].
- The Installation Assistant will open.

9.3 Configuring the Country Data Set

QUALIFIED PERSON

By default, the inverter is set to a universally valid country data set. You can adjust the country data set for the installation site retroactively.

The country data set must be set correctly.

If you select a country data set which is not valid for your country and purpose, it can cause a disturbance in the PV system and lead to problems with the grid operator. When selecting the country data set, you must always observe the locally applicable standards and directives as well as the properties of the PV system (e.g. PV system size, grid-connection point).

- If you are not sure which country data set is valid for your country or purpose, contact your grid operator for information on which country data set is to be configured.

The basic procedure for changing operating parameters is explained in another section (see Section 9.1 "Changing Operating Parameters", page 58).

Procedure:

- In the parameter group **Grid monitoring > Grid monitoring** select the parameter **Set country standard** and set the required country data set.

9.4 Configuring Feed-In Management

QUALIFIED PERSON

Starting the installation assistant

1. Activate the user interface (see Section 8.1, page 48).
2. Log in as **Installer**.
3. Start the installation assistant (see Section 9.2, page 59).
4. Select [**Save and continue**] after each step up until the step **Configure grid management service**.
5. Make the settings as described in the following.

Connected line conductors

- From the drop-down list **Connected line conductors**, select the line conductor to which the inverter is connected. This will ensure the functionality of the unbalanced load limitation.

Feed-in management at the grid-connection point

Making settings for Flexible Storage System without Sunny Home Manager

1. Set **Feed-in management at the grid-connection point** to [On].
2. Enter the power of the entire PV system in the field **Nominal PV system power**.
3. In the drop-down list **Operating mode of active power limitation at the grid-connection point**, select whether active power limitation is to be performed via a fixed specification in percent or in watts.
4. In the field **Set active power limit at the grid-connection point**, enter the value to which the active power at the grid-connection point is to be limited.

Making settings for Flexible Storage System with Sunny Home Manager

- Set **Feed-in management at the grid-connection point** to [Off].

Activating unbalanced load limitation

- If there are single-phase PV inverters in the system and unbalanced load limitation is requested, set **Unbalanced load limitation** to [On] and enter the maximum permissible unbalanced load in the field **Maximum unbalanced load**.
- If there are three-phase PV inverters in the system, set **Unbalanced load limitation** to [Off].

Setting PV inverter feed-in management

1. Activate the PV inverter user interface.
2. Log in as **Installer**.
3. Start the installation assistant on the PV inverter user interface.
4. Select [Save and continue] after each step up until the step **Configure grid management service**.
5. Set **System control and power limitation** to [On].
6. In the drop-down list **Operating mode active power**, select the entry **Active power limitation P via system control**.
7. In the drop-down list **Operating mode for absent system control**, select the entry **Use fallback setting**.
8. In the field **Fallback active power P**, enter the same value as the one entered for the battery inverter. Where necessary, convert this value into a percentage. This ensures that in systems with Sunny Home Manager, the correct fallback value will be adopted in the event of a communication breakdown between Sunny Home Manager and inverter.

9. In the field **Timeout**, enter the time that the PV inverter is to wait before it limits its nominal power to the set fallback value.
10. If, in the event of a 0% or 0 W specification, the PV inverter is not permitted to feed small amounts of active power into the utility grid, select the entry **Yes** in the drop-down list **Grid disconnection at zero export**. This ensures that in the event of a 0% or 0 W specification, the inverter disconnects from the grid and does not feed active power into the utility grid.

9.5 Configuring the Modbus Function

QUALIFIED PERSON

The Modbus interface is deactivated by default and the communication ports 502 set. In order to access SMA inverters with SMA Modbus® or SunSpec® Modbus®, the Modbus interface must be activated. After activating the interface, the communication ports of both IP protocols can be changed.

For information on commissioning and configuration of the Modbus interface, see the Technical Information "SMA Modbus® Interface" or in the Technical Information "SunSpec® Modbus® Interface" at www.SMA-Solar.com.

For information on which Modbus registers are supported, see the Technical Descriptions "SMA Modbus® Interface" or "SunSpec® Modbus® Interface" at www.SMA-Solar.com.

Data security during activated Modbus interface

If you activate the Modbus interface, there is a risk that unauthorized users may access and manipulate the data or devices in your PV system.

- Take appropriate protective measures such as:
 - Set up a firewall.
 - Close unnecessary network ports.
 - Only enable remote access via VPN tunnel.
 - Do not set up port forwarding at the communication port in use.
 - In order to deactivate the Modbus interface, reset the inverter to default settings or deactivate the activated parameter again.

Deactivate the dynamic active power limitation for the PV inverters when controlled via Modbus

If the PV inverters and the battery inverter are controlled in a PV system via Modbus, the dynamic active power limitation of the PV inverters must be deactivated.

Procedure:

- Activate the Modbus interface and adjust the communication ports if necessary (see the Technical Information "SMA Modbus® Interface" or "SunSpec® Modbus® Interface" at www.SMA-Solar.com).

9.6 Saving the Configuration in a File

You can save the current configuration of the inverter in a file. You can use this file as a data backup for this inverter and then import this file into this inverter again or another inverter to configure the inverter. When saving, only the device parameters will be saved, not any passwords.

Procedure:

1. Activate the user interface (see Section 8.1, page 48).
2. Log into the user interface (see Section 8.2, page 51).
3. Select the menu **Device Configuration**.
4. Select [**Settings**].
5. In the context menu, select [**Saving the configuration in a file**].
6. Follow the instructions in the dialog.

9.7 Adopting a Configuration from a File

QUALIFIED PERSON

To configure the inverter, you can adopt the configuration from a file. To be able to do this, you must first save the configuration of another inverter in a file (see Section 9.6 "Saving the Configuration in a File", page 63). When saving, only the device parameters will be adopted, not any passwords.

Requirements:

- The SMA Grid Guard code must be available (see "Application for SMA Grid Guard Code" at www.SMA-Solar.com).
- Changes to grid-relevant parameters must be approved by the responsible grid operator.

Procedure:

1. Activate the user interface (see Section 8.1, page 48).
2. Log into the user interface as an **Installer**.
3. Select the menu **Device Configuration**.
4. Select [**Settings**].
5. In the context menu, select [**Adopting the configuration from a file**].
6. Follow the instructions in the dialog.

9.8 Activate WPS Function

- Activate the WPS function on the inverter. To do this, tap on the enclosure lid of the inverter twice.
 - The blue LED flashes quickly for approx. two minutes. The WPS function is active.

9.9 Switching WLAN On and Off

The inverter is equipped with an activated WLAN interface as standard. If you do not want to use WLAN, you can switch the WLAN function off and switch it on again whenever needed. In doing so, you can switch the WLAN direct connection and the WLAN connection in the local network on independently of each other.

Switching on the WLAN function only possible via Ethernet connection

If you switch off both the WLAN function for the direct connection and for the connection in the local network, access to the inverter user interface and therefore reactivation of the WLAN interface is only possible via an Ethernet connection.

The basic procedure for changing operating parameters is explained in another section (see Section 9.1 "Changing Operating Parameters", page 58).

Switching WLAN Off

If you would like to switch the WLAN function off completely, you must switch off both the direct connection and the connection in the local network.

Procedure:

- To switch off the direct connection in the parameter group **PV system communication > WLAN**, select the parameter **Soft-access-point is turned on** and set this to **No**.
- To switch off the connection in the local network in the parameter group **PV system communication > WLAN**, select the parameter **WLAN is turned on** and set this to **No**.

Switching WLAN On

If you have switched the WLAN function for direct connection or for connection in the local network off, you can switch the WLAN function back on in accordance with the following procedure.

Requirement:

- If the WLAN function was previously switched off completely, the inverter must be connected to a computer or router via Ethernet.

Procedure:

- To switch on the WLAN direct connection, in the parameter group **PV system communication > WLAN**, select the parameter **Soft-access-point is turned on** and set this to **Yes**.
- To switch on the WLAN connection in the local network, in the parameter group **System communication > WLAN**, select the parameter **WLAN is turned on** and set this to **Yes**.

9.10 Activating the Receipt of Control Signals (Only for Italy)

QUALIFIED PERSON

In order for PV systems in Italy to receive control commands from the grid operator, set the following parameters.

The basic procedure for changing operating parameters is explained in another section (see Section 9.1 "Changing Operating Parameters", page 58).

Parameters	Value/range	Resolution	Default
Application ID	0 to 16384	1	16384
GOOSE-Mac address	01:0C:CD:01:00:00 to 01:0C:CD:01:02:00	1	01:0C:CD:01:00:00

Procedure:

1. Select the parameter group **External communication > IEC 61850 configuration**.
 2. In the field **Application ID**, enter the application ID of the grid operator gateway. You will receive this value from your grid operator. You can enter a value between 0 and 16384. The value 16384 indicates "deactivated".
 3. In the field **GOOSE-Mac address**, enter the MAC address of the grid operator gateway from which the inverter is to receive the control commands. You will receive this value from your grid operator.
- The receipt of control signals from the grid operator is activated.

9.11 Deactivating Grounding Conductor Monitoring

QUALIFIED PERSON

If the inverter is to be installed in an IT network or another grid configuration in which deactivation of the grounding conductor monitoring is required, deactivate the grounding conductor monitoring as follows.

The basic procedure for changing operating parameters is explained in another section (see Section 9.1 "Changing Operating Parameters", page 58).

Procedure:

- In the parameter group **Grid monitoring > Grid monitoring > Country standard** set the parameter **PE connection monitoring** to **Off**.

9.12 Configuring the Energy Meter

QUALIFIED PERSON

You can add an energy meter to your PV system or replace an existing energy meter.

The basic procedure for changing operating parameters is explained in another section (see Section 9.1 "Changing Operating Parameters", page 58).

i Removing a detected energy meter from the PV system

If only one energy meter is detected by the inverter, this will be added to the PV system automatically. Removal via the menu **Device configuration** is not possible in this case. To remove the energy meter from the PV system, proceed as follows:

- In the parameter group **PV system communication > Measured values > Meter on Speedwire** set the parameter **Serial number** to any number (e.g. 1). In this way, instead of the energy meter detected, the PV system will add a fictitious energy meter to which the inverter cannot establish communication.

Procedure:

1. Activate the user interface (see Section 8.1, page 48).
2. Log in as **Installer**.
3. Start the installation assistant (see Section 9.2, page 59).
4. In the context menu, select **[Start the installation assistant]**.
5. Select **[Save and next]** until you get to the step **Meter configuration**.
6. Add or replace the desired energy meter.

9.13 Setting the heating mode for the battery

The inverter features a heating mode for "Tesla Daily Powerwall" batteries from Tesla Energy. The heating mode helps conserve the battery at low temperatures. This way, you can increase the service life of the battery. The heating mode is normally set such that the battery is automatically if temperatures are too low and enough charging power is available. The heating energy is covered by excess PV power.

The heating mode should always be activated if the battery is installed on a location where temperatures below -10°C are expected and, in this case, has to be charged immediately when excess PV power is available. The heating energy will be drawn from the utility grid.

The heating mode for the battery can be deactivated if the battery is installed on a location where the temperature does not fall below 10°C .

To modify the default setting of the heating mode for the battery, proceed as described below.

The basic procedure for changing operating parameters is explained in another section (see Section 9.1 "Changing Operating Parameters", page 58).

Procedure:

1. Select the parameter group **Battery > Operation > Battery**.
2. To activate the heating mode, set the parameter **Heating mode** to **On**.
3. To set the automatic heating mode, set the parameter **Heating mode** to **Automatic**.
4. To deactivate the heating mode, set the parameter **Heating mode** to **Off**.

10 Disconnecting the Inverter from Voltage Sources

⚠ QUALIFIED PERSON

Prior to performing any work on the inverter, always disconnect it from all voltage sources as described in this section. Always adhere to the prescribed sequence.

Procedure:

1. Disconnect the AC circuit breaker and secure it against reconnection.
2. If the battery has a load-break switch, then switch it off (see the documentation of the battery manufacturer).
3. Unscrew the swivel nuts from the cable glands on the connection cap.

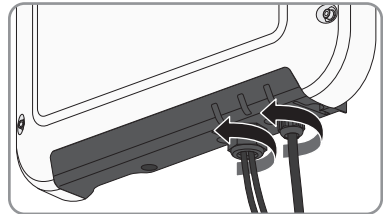

4. Unscrew the screws of the connection cap with a Torx screwdriver (TX 20) and remove the connection cap towards the bottom.

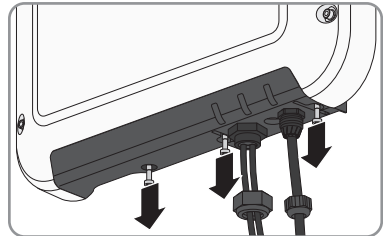

5. Ensure that no voltage is present between **L** and **N** and **L** and \oplus on the connecting terminal plate for the AC connection using a suitable measuring device. To do so, insert the test probe (maximum diameter: 2 mm) into each round opening of the connecting terminal plate.
6. Release and disconnect the connecting terminal plate using the sliders located at the side.

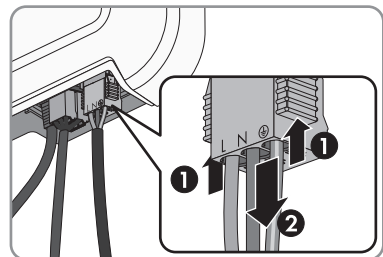

7. Remove the plug with the battery communication cable.

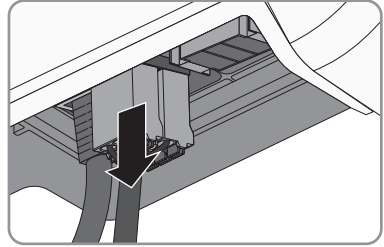

8. Release and remove the plug of the network cable.

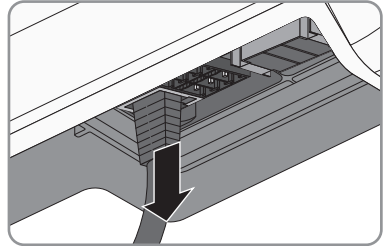

9. Use a current clamp to ensure that no current is present in the DC conductors.

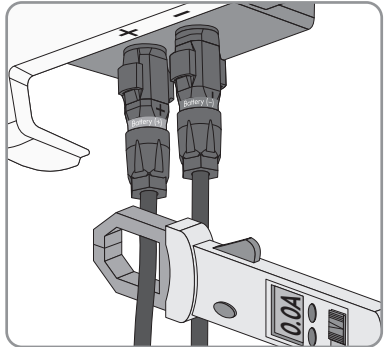

10. Release and remove the DC connectors. To do this, insert a flat-blade screwdriver or an angled screwdriver (blade width: 3.5 mm) into one of the slide slots and pull the DC connectors out in a downward direction. Do not pull on the cable.

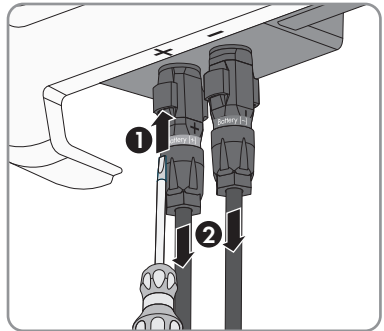

11. Ensure that no voltage is present at the DC inputs on the inverter using a suitable measuring device.

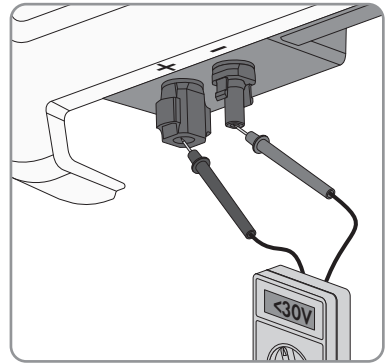

11 Cleaning the Inverter

NOTICE**Damage to the inverter due to the use of cleaning agents**

- If the inverter is dirty, clean the enclosure, the enclosure lid, the type label and the LEDs using only clean water and a cloth.
- Ensure that the inverter is free of dust, foliage and other dirt.

12 Troubleshooting

12.1 Forgotten Password

If you have forgotten the password for the inverter, you can unlock the inverter with a Personal Unlocking Key (PUK). For each inverter, there is one PUK for each user group (**User** and **Installer**). Useful hint: With PV systems in Sunny Portal, you can also assign a new password via Sunny Portal for the user group **Installer**. The password for the user group **Installer** is the same as the system password in Sunny Portal.

Procedure:

1. Request PUK (application form available at www.SMA-Solar.com).
2. Activate the user interface (see Section 8.1, page 48).
3. Enter the PUK instead of the password into the field **Password**.
4. Select **Login**.
5. Call up the menu **Device Parameters**.
6. Select [**Edit parameters**].
7. In the parameter group **User Rights > Access Control** change the password of the desired user group.
8. Select [**Save all**] to save the changes.

PV Systems in Sunny Portal

The password for the user group **Installer** is also the system password for the PV system in Sunny Portal. Changing the password of the user group **Installer** can lead to the inverter no longer being able to be reached by Sunny Portal.

- Assign the changed password of the user group **Installer** as the new system password in Sunny Portal (see the Sunny Portal user manual at www.SMA-Solar.com).

12.2 Event Messages

Event number	Message, cause and corrective measures
101 to 105	<div data-bbox="292 236 594 272" style="background-color: #cccccc; padding: 2px;">⚠ QUALIFIED PERSON</div> <p data-bbox="292 288 389 317">Grid fault</p> <p data-bbox="292 325 981 379">The grid voltage or grid impedance at the connection point of the inverter is too high. The inverter has disconnected from the utility grid.</p> <p data-bbox="292 387 508 416">Corrective measures:</p> <ul data-bbox="311 424 988 547" style="list-style-type: none"> <li data-bbox="311 424 930 478">• Ensure that the correct country data set has been configured (see Section 9.3, page 60). <li data-bbox="311 491 988 547">• Check whether the grid voltage at the connection point of the inverter is permanently in the permissible range. <p data-bbox="334 560 992 671">If the grid voltage is outside the permissible range due to local grid conditions, contact the grid operator. The grid operator must agree with an adjustment of the voltage at the feed-in point or with a change of the monitored operating limits.</p> <p data-bbox="334 683 997 767">If the grid voltage is permanently within the permissible range and this message is still displayed, contact the Service (see Section 16 "Contact", page 106).</p>
202 to 206	<div data-bbox="292 778 594 815" style="background-color: #cccccc; padding: 2px;">⚠ QUALIFIED PERSON</div> <p data-bbox="292 831 389 860">Grid fault</p> <p data-bbox="292 868 992 952">The utility grid has been disconnected, the AC cable is damaged or the grid voltage at the connection point of the inverter is too low. The inverter has disconnected from the utility grid.</p> <p data-bbox="292 960 508 989">Corrective measures:</p> <ul data-bbox="311 997 988 1198" style="list-style-type: none"> <li data-bbox="311 997 781 1026">• Make sure that the circuit breaker is switched on. <li data-bbox="311 1034 930 1088">• Ensure that the AC cable is not damaged and that it is connected correctly. <li data-bbox="311 1101 908 1129">• Ensure that the country data set has been configured correctly. <li data-bbox="311 1142 988 1198">• Check whether the grid voltage at the connection point of the inverter is permanently in the permissible range. <p data-bbox="334 1211 992 1323">If the grid voltage is outside the permissible range due to local grid conditions, contact the grid operator. The grid operator must agree with an adjustment of the voltage at the feed-in point or with a change of the monitored operating limits.</p> <p data-bbox="334 1334 997 1418">If the grid voltage is permanently within the permissible range and this message is still displayed, contact the Service (see Section 16 "Contact", page 106).</p>

Event number	Message, cause and corrective measures
302	<p>Active power limited AC voltage</p> <p>The inverter has reduced its power due to a too-high grid voltage to ensure grid stability.</p> <p>Corrective measures:</p> <ul style="list-style-type: none"> • If possible, check the grid voltage and observe how often fluctuations occur. If fluctuations occur frequently and this message is displayed often, contact the grid operator and request approval to change the operating parameters of the inverter. If the grid operator gives his approval, discuss any changes to the operating parameters with Service (see Section 16 "Contact", page 106).
401 to 404	<p>⚠ QUALIFIED PERSON</p> <p>Grid fault</p> <p>The inverter has disconnected from the utility grid. A stand-alone grid or a very large change in the power frequency was detected.</p> <p>Corrective measures:</p> <ul style="list-style-type: none"> • Check the grid connection for significant short-term frequency fluctuations.
501	<p>⚠ QUALIFIED PERSON</p> <p>Grid fault</p> <p>The power frequency is not within the permissible range. The inverter has disconnected from the utility grid.</p> <p>Corrective measures:</p> <ul style="list-style-type: none"> • If possible, check the power frequency and observe how often fluctuations occur. <p>If fluctuations occur frequently and this message is displayed often, contact the grid operator and request approval to change the operating parameters of the inverter.</p> <p>If the grid operator gives his approval, discuss any changes to the operating parameters with Service (see Section 16 "Contact", page 106).</p>

Event number	Message, cause and corrective measures
507	<p data-bbox="311 185 594 220">⚠ QUALIFIED PERSON</p> <p data-bbox="288 236 647 263">Active power limited AC frequency</p> <p data-bbox="288 272 986 327">The inverter has reduced its power due to a too-high power frequency to ensure grid stability.</p> <p data-bbox="288 336 508 360">Corrective measures:</p> <ul data-bbox="311 370 1005 539" style="list-style-type: none"> <li data-bbox="311 370 1005 539">• If possible, check the power frequency and observe how often fluctuations occur. If fluctuations occur frequently and this message is displayed often, contact the grid operator and request approval to change the operating parameters of the inverter. If the grid operator gives his approval, discuss any changes to the operating parameters with Service (see Section 16 "Contact", page 106).
601	<p data-bbox="311 552 594 587">⚠ QUALIFIED PERSON</p> <p data-bbox="288 603 393 630">Grid fault</p> <p data-bbox="288 639 978 694">The inverter has detected an excessively high proportion of direct current in the grid current.</p> <p data-bbox="288 703 508 727">Corrective measures:</p> <ul data-bbox="311 737 967 831" style="list-style-type: none"> <li data-bbox="311 737 967 767">• Check the grid connection for direct current. <li data-bbox="311 777 967 831">• If this message is displayed frequently, contact the grid operator and check whether the monitoring threshold on the inverter can be raised.
701	<p data-bbox="311 847 594 882">⚠ QUALIFIED PERSON</p> <p data-bbox="288 898 676 925">Frq. not permitted > Check parameter</p> <p data-bbox="288 935 992 989">The power frequency is not within the permissible range. The inverter has disconnected from the utility grid.</p> <p data-bbox="288 999 508 1023">Corrective measures:</p> <ul data-bbox="311 1032 997 1278" style="list-style-type: none"> <li data-bbox="311 1032 997 1182">• If possible, check the power frequency and observe how often fluctuations occur. If fluctuations occur frequently and this message is displayed often, contact the grid operator and request approval to change the operating parameters of the inverter. <li data-bbox="311 1192 997 1278">• If the grid operator gives his approval, discuss any changes to the operating parameters with Service (see Section 16 "Contact", page 106).

Event number	Message, cause and corrective measures
901	<p>⚠ QUALIFIED PERSON</p> <p>No PE connection > Check connection</p> <p>The grounding conductor is not correctly connected.</p> <p>Corrective measures:</p> <ul style="list-style-type: none"> • Ensure that the grounding conductor is correctly connected (see Section 6.2.2 "Connecting the Inverter to the Utility Grid", page 28).
1001	<p>⚠ QUALIFIED PERSON</p> <p>L/N swapped > Check connection</p> <p>The connection of L and N is swapped.</p> <p>Corrective measures:</p> <ul style="list-style-type: none"> • Ensure that L and N are correctly connected (see Section 6.2.2 "Connecting the Inverter to the Utility Grid", page 28).
1101	<p>⚠ QUALIFIED PERSON</p> <p>Installation fault > Check connection</p> <p>A second line conductor is connected to N.</p> <p>Corrective measures:</p> <ul style="list-style-type: none"> • Connect the neutral conductor to N (see Section 6.2.2 "Connecting the Inverter to the Utility Grid", page 28).
1302	<p>⚠ QUALIFIED PERSON</p> <p>Waiting for grid voltage > Installation failure grid connection > Check grid and fuses</p> <p>L or N not connected.</p> <p>Corrective measures:</p> <ul style="list-style-type: none"> • Ensure that L and N are connected (see Section 6.2.2 "Connecting the Inverter to the Utility Grid", page 28). • Ensure that the AC cable is not damaged and that it is connected correctly (see Section 6.2.2 "Connecting the Inverter to the Utility Grid", page 28). • Make sure that the circuit breaker is switched on.

Event number	Message, cause and corrective measures
1501	<p data-bbox="311 183 596 220">⚠ QUALIFIED PERSON</p> <p data-bbox="288 236 529 263">Reconnection fault grid</p> <p data-bbox="288 271 994 355">The changed country data set or the value of a parameter you have set does not correspond to the local requirements. The inverter cannot connect to the utility grid.</p> <p data-bbox="288 363 508 387">Corrective measures:</p> <ul data-bbox="311 395 1012 451" style="list-style-type: none"> • Ensure that the country data set has been configured correctly. To do this, select the parameter Set country standard and check the value.
3301	<p data-bbox="311 467 596 504">⚠ QUALIFIED PERSON</p> <p data-bbox="288 520 490 547">Unstable operation</p> <p data-bbox="288 555 1003 611">There is not enough power at the DC input of the inverter for stable operation. The inverter cannot connect to the utility grid.</p> <p data-bbox="288 619 508 643">Corrective measures:</p> <ul data-bbox="311 651 854 683" style="list-style-type: none"> • Ensure that the correct battery type has been configured.
3401	<p data-bbox="311 691 596 727">⚠ QUALIFIED PERSON</p> <p data-bbox="288 743 697 770">DC overvoltage > Disconnect generator</p> <p data-bbox="288 778 820 802">Overvoltage at the DC input. This can destroy the inverter.</p> <p data-bbox="288 810 508 834">Corrective measures:</p> <ul data-bbox="311 842 983 1137" style="list-style-type: none"> • Immediately disconnect the inverter from all voltage sources (see Section 10, page 67). • Check whether the DC voltage is below the maximum input voltage of the inverter. If the DC voltage is below the maximum DC voltage of the inverter, reconnect the DC connectors to the inverter. • If the DC voltage is above the maximum DC voltage of the inverter, ensure that the correct battery has been selected. • If this message is repeated frequently, contact the Service (see Section 16 "Contact", page 106).
3501	<p data-bbox="311 1153 596 1190">⚠ QUALIFIED PERSON</p> <p data-bbox="288 1206 658 1233">Insulation failure > Check generator</p> <p data-bbox="288 1241 804 1265">The inverter has detected a ground fault on the DC side.</p> <p data-bbox="288 1273 508 1297">Corrective measures:</p> <ul data-bbox="311 1305 813 1339" style="list-style-type: none"> • Check the battery and DC cabling for ground faults.

Event number	Message, cause and corrective measures
3601	<p>⚠ QUALIFIED PERSON</p> <p>High discharge curr. > Check generator</p> <p>The leakage current of the inverter and the battery is too high. There is a ground fault, a residual current or a malfunction.</p> <p>The inverter interrupts parallel grid operation immediately after exceeding a threshold. When the fault is eliminated, the inverter automatically reconnects to the utility grid.</p> <p>Corrective measures:</p> <ul style="list-style-type: none"> • Check the battery and DC cabling for ground faults.
3701	<p>⚠ QUALIFIED PERSON</p> <p>Resid.curr.too.high > Check generator</p> <p>The inverter detected a residual current due to brief grounding of the battery or the DC cabling.</p> <p>Corrective measures:</p> <ul style="list-style-type: none"> • Check the battery and DC cabling for ground faults.
3801	<p>⚠ QUALIFIED PERSON</p> <p>DC overcurrent > Check generator</p> <p>Overcurrent at the DC input. The inverter briefly interrupts feed-in operation.</p> <p>Corrective measures:</p> <ul style="list-style-type: none"> • If this message is displayed frequently, ensure that the battery has been correctly connected and that the correct battery has been selected.
6607 to 6608	<p>⚠ QUALIFIED PERSON</p> <p>Self-diagnosis > Battery overcurrent</p> <p>The battery detected an overcurrent on the DC side.</p> <p>Corrective measures:</p> <ul style="list-style-type: none"> • Ensure that the battery is correct. • If this message is displayed frequently, contact the Service (see Section 16 "Contact", page 106).
6701 to 6702	<p>⚠ QUALIFIED PERSON</p> <p>Communication disturbed</p> <p>Error in the communication processor. The inverter is still in parallel grid operation.</p> <p>Corrective measures:</p> <ul style="list-style-type: none"> • If this message is displayed frequently, contact the Service (see Section 16 "Contact", page 106).

Event number	Message, cause and corrective measures
7201 to 7202	<p>⚠ QUALIFIED PERSON</p> <p>Data stor. not poss. Internal error. The inverter is still in parallel grid operation.</p> <p>Corrective measures:</p> <ul style="list-style-type: none"> • Contact the Service (see Section 16 "Contact", page 106).
7303	<p>⚠ QUALIFIED PERSON</p> <p>Update main CPU failed The cause must be determined by the Service.</p> <p>Corrective measures:</p> <ul style="list-style-type: none"> • Contact the Service (see Section 16 "Contact", page 106).
7324	<p>⚠ QUALIFIED PERSON</p> <p>Wait for update conditions The testing of the update conditions was not successful. The firmware update package is not suitable for this inverter.</p> <p>Corrective measures:</p> <ul style="list-style-type: none"> • Retry update. • Ensure that the selected update file is suitable for this inverter. • If this message is displayed again, contact the Service (see Section 16 "Contact", page 106).
7331	<p>Update transport started Update file is being copied.</p>
7332	<p>Update transport successful Update file was copied successfully to the inverter's internal memory.</p>
7333	<p>⚠ QUALIFIED PERSON</p> <p>Update transport failed Update file could not be copied to the inverter's internal memory. In the event of connection with the inverter via WLAN, a poor connection quality can be the cause.</p> <p>Corrective measures:</p> <ul style="list-style-type: none"> • Retry update. • For WLAN connection: Improve the WLAN connection quality (e.g. via WLAN repeater) or establish connection with the inverter via Ethernet. • If this message is displayed again, contact the Service (see Section 16 "Contact", page 106).

Event number	Message, cause and corrective measures
7337	<p data-bbox="292 183 596 220">⚠ QUALIFIED PERSON</p> <p data-bbox="292 236 486 263">Update BMS failed</p> <p data-bbox="292 272 748 300">The firmware of the battery could not be updated.</p> <p data-bbox="292 309 508 336">Corrective measures:</p> <ul data-bbox="311 346 978 478" style="list-style-type: none"> <li data-bbox="311 346 777 373">• Make sure that the correct update file was used. <li data-bbox="311 383 460 410">• Retry update. <li data-bbox="311 419 978 478">• If this message is displayed again, contact the Service (see Section 16 "Contact", page 106).
7341	<p data-bbox="292 486 490 513">Update Bootloader</p> <p data-bbox="292 523 723 550">The inverter is performing a bootloader update.</p>
7342	<p data-bbox="292 563 596 600">⚠ QUALIFIED PERSON</p> <p data-bbox="292 616 555 643">Update Bootloader failed</p> <p data-bbox="292 652 564 679">The bootloader update failed.</p> <p data-bbox="292 689 508 716">Corrective measures:</p> <ul data-bbox="311 726 978 821" style="list-style-type: none"> <li data-bbox="311 726 460 753">• Retry update. <li data-bbox="311 762 978 821">• If this message is displayed again, contact the Service (see Section 16 "Contact", page 106).
7347	<p data-bbox="292 829 596 866">⚠ QUALIFIED PERSON</p> <p data-bbox="292 882 463 909">Incompatible file</p> <p data-bbox="292 919 757 946">The configuration file is not suitable for this inverter.</p> <p data-bbox="292 956 508 983">Corrective measures:</p> <ul data-bbox="311 992 950 1058" style="list-style-type: none"> <li data-bbox="311 992 950 1019">• Ensure that the selected configuration file is suitable for this inverter. <li data-bbox="311 1029 452 1058">• Retry import.
7348	<p data-bbox="292 1066 596 1102">⚠ QUALIFIED PERSON</p> <p data-bbox="292 1118 493 1145">Incorrect file format</p> <p data-bbox="292 1155 885 1182">The configuration file is not of the required format or is damaged.</p> <p data-bbox="292 1192 508 1219">Corrective measures:</p> <ul data-bbox="311 1228 997 1318" style="list-style-type: none"> <li data-bbox="311 1228 997 1287">• Ensure that the selected configuration file is of the required format and is not damaged. <li data-bbox="311 1297 452 1318">• Retry import.

Event number	Message, cause and corrective measures
7349	<p data-bbox="311 188 595 220">⚠ QUALIFIED PERSON</p> <p data-bbox="288 236 716 263">Incorrect login rights for configuration file</p> <p data-bbox="288 271 985 327">The user group logged in does not have the user rights necessary to be able to import a configuration.</p> <p data-bbox="288 335 509 359">Corrective measures:</p> <ul data-bbox="311 367 616 438" style="list-style-type: none"> <li data-bbox="311 367 509 391">• Log in as Installer. <li data-bbox="311 406 616 438">• Import configuration file again.
7350	<p data-bbox="288 446 722 475">Transfer of a configuration file has started</p> <p data-bbox="288 483 666 510">The configuration file is being transferred.</p>
7351	<p data-bbox="288 526 442 555">Update WLAN</p> <p data-bbox="288 563 688 590">The inverter is updating the WLAN module.</p>
7352	<p data-bbox="311 606 595 635">⚠ QUALIFIED PERSON</p> <p data-bbox="288 651 616 678">Update of WLAN not successful</p> <p data-bbox="288 686 655 713">The update of the WLAN module failed.</p> <p data-bbox="288 721 509 745">Corrective measures:</p> <ul data-bbox="311 753 980 853" style="list-style-type: none"> <li data-bbox="311 753 459 777">• Retry update. <li data-bbox="311 793 980 853">• If this message is displayed again, contact the Service (see Section 16 "Contact", page 106).
7353	<p data-bbox="288 861 576 890">Update time zone database</p> <p data-bbox="288 898 728 925">The inverter is updating the time zone database.</p>
7354	<p data-bbox="311 941 595 970">⚠ QUALIFIED PERSON</p> <p data-bbox="288 986 750 1013">Update of time zone database not successful</p> <p data-bbox="288 1021 700 1048">The update of the time zone database failed.</p> <p data-bbox="288 1056 509 1080">Corrective measures:</p> <ul data-bbox="311 1088 980 1197" style="list-style-type: none"> <li data-bbox="311 1088 459 1112">• Retry update. <li data-bbox="311 1128 980 1197">• If this message is displayed again, contact the Service (see Section 16 "Contact", page 106).
7355	<p data-bbox="288 1204 448 1233">Update WebUI</p> <p data-bbox="288 1241 744 1268">The inverter is updating the inverter user interface.</p>

Event number	Message, cause and corrective measures
7356	<p data-bbox="308 183 593 215">⚠ QUALIFIED PERSON</p> <p data-bbox="285 231 655 263">Update of the WebUI not successful</p> <p data-bbox="285 268 716 300">The update of the inverter user interface failed.</p> <p data-bbox="285 304 509 336">Corrective measures:</p> <ul data-bbox="308 341 980 438" style="list-style-type: none"> <li data-bbox="308 341 459 373">• Retry update. <li data-bbox="308 378 980 438">• If this message is displayed again, contact the Service (see Section 16 "Contact", page 106).
8003	<p data-bbox="308 446 593 478">⚠ QUALIFIED PERSON</p> <p data-bbox="285 494 593 526">Active power limited derating</p> <p data-bbox="285 531 1002 595">The inverter has reduced its power output for more than ten minutes due to excessive temperature.</p> <p data-bbox="285 600 509 632">Corrective measures:</p> <ul data-bbox="308 636 980 813" style="list-style-type: none"> <li data-bbox="308 636 980 700">• Clean the cooling fins on the rear of the enclosure and the air ducts on the top using a soft brush. <li data-bbox="308 705 767 737">• Ensure that the inverter has sufficient ventilation. <li data-bbox="308 742 952 774">• Ensure that the ambient temperature 40°C has not been exceeded. <li data-bbox="308 778 918 813">• Ensure that the inverter is not exposed to direct solar irradiation.
9002	<p data-bbox="308 821 593 853">⚠ QUALIFIED PERSON</p> <p data-bbox="285 869 599 901">SMA Grid Guard code invalid</p> <p data-bbox="285 906 1008 970">The SMA Grid Guard code entered is incorrect. The operating parameters are still protected and cannot be changed.</p> <p data-bbox="285 975 509 1007">Corrective measures:</p> <ul data-bbox="308 1011 711 1037" style="list-style-type: none"> <li data-bbox="308 1011 711 1037">• Enter the correct SMA Grid Guard code.
9003	<p data-bbox="285 1045 532 1077">Grid parameter locked</p> <p data-bbox="285 1082 1008 1166">Changes to the grid parameters are now blocked. In order to be able to make changes to the grid parameters, from now on you must log in using the SMA Grid Guard code.</p>

Event number	Message, cause and corrective measures
9005	<p data-bbox="311 188 594 220">⚠ QUALIFIED PERSON</p> <p data-bbox="288 236 561 261">Waiting for host computer</p> <p data-bbox="288 272 664 298">This error can have the following causes:</p> <ul data-bbox="311 308 956 371" style="list-style-type: none"> <li data-bbox="311 308 751 333">• The parameters to be changed are protected. <li data-bbox="311 344 956 371">• The DC voltage at the DC input is not sufficient to run the main CPU. <p data-bbox="288 387 508 413">Corrective measures:</p> <ul data-bbox="311 422 932 515" style="list-style-type: none"> <li data-bbox="311 422 639 448">• Enter the SMA Grid Guard code. <li data-bbox="311 459 932 515">• Ensure that at least the DC start voltage is available (green LED is flashing, pulsing or glowing).
9007	<p data-bbox="311 534 594 566">⚠ QUALIFIED PERSON</p> <p data-bbox="288 582 432 608">Abort self-test</p> <p data-bbox="288 619 650 644">The self-test (Italy only) was terminated.</p> <p data-bbox="288 655 508 681">Corrective measures:</p> <ul data-bbox="311 691 706 716" style="list-style-type: none"> <li data-bbox="311 691 706 716">• Ensure that the AC connection is correct.
9301	<p data-bbox="311 730 594 762">⚠ QUALIFIED PERSON</p> <p data-bbox="288 778 516 804">New battery detected</p> <p data-bbox="288 815 658 841">The inverter has detected a new battery.</p> <p data-bbox="288 852 508 877">Corrective measures:</p> <ul data-bbox="311 887 1003 1034" style="list-style-type: none"> <li data-bbox="311 887 1003 967">• Ensure that the correct battery type has been configured when replacing the battery. To do so, start the installation assistant and check the battery type set. <li data-bbox="311 978 1003 1034">• If this message occurs even though the battery was not replaced, contact Service (see Section 16 "Contact", page 106).
9303	<p data-bbox="311 1050 594 1082">⚠ QUALIFIED PERSON</p> <p data-bbox="288 1098 701 1123">The service life of the battery is expiring</p> <p data-bbox="288 1134 936 1190">The minimum service life defined by the battery manufacturer has been reached.</p> <p data-bbox="288 1201 508 1227">Corrective measures:</p> <ul data-bbox="311 1236 904 1262" style="list-style-type: none"> <li data-bbox="311 1236 904 1262">• Contact the battery manufacturer and discuss what to do next.

Event number	Message, cause and corrective measures
9304	<p data-bbox="311 188 595 220">⚠ QUALIFIED PERSON</p> <p data-bbox="288 236 845 263">Fault in battery connection > Check battery connection</p> <p data-bbox="288 274 647 300">This message can have several causes:</p> <ul data-bbox="311 308 960 443" style="list-style-type: none"> <li data-bbox="311 308 960 363">• The battery power cable is either not connected to the battery or not properly connected to the inverter. <li data-bbox="311 371 960 399">• The CAN communication between battery and inverter is disturbed. <li data-bbox="311 406 520 443">• The battery is faulty. <p data-bbox="288 454 509 481">Corrective measures:</p> <ul data-bbox="311 489 991 750" style="list-style-type: none"> <li data-bbox="311 489 991 545">• Make sure that the battery communication cable and the battery power cable are properly connected to the inverter as well as to the battery. <li data-bbox="311 553 916 609">• Ensure that the firmware versions of the inverter and battery are compatible with each other. <li data-bbox="311 617 725 644">• Ensure the perfect operation of the battery. <li data-bbox="311 652 972 750">• If the battery communication cable and the battery power cable have been properly connected and the correct operation of the battery is ensured, contact Service (see Section 16 "Contact", page 106).
9305	<p data-bbox="311 770 595 802">⚠ QUALIFIED PERSON</p> <p data-bbox="288 818 591 845">Unauthorized battery system</p> <p data-bbox="288 853 711 880">The inverter has detected an incorrect battery.</p> <p data-bbox="288 888 509 916">Corrective measures:</p> <ul data-bbox="311 924 927 981" style="list-style-type: none"> <li data-bbox="311 924 927 981">• Only operate batteries with the inverter approved by SMA Solar Technology AG.
9306	<p data-bbox="311 994 595 1026">⚠ QUALIFIED PERSON</p> <p data-bbox="288 1042 580 1069">Deviation in battery voltage</p> <p data-bbox="288 1077 994 1133">Too high a deviation between the battery and DC voltage of inverter was detected.</p> <p data-bbox="288 1141 509 1168">Corrective measures:</p> <ul data-bbox="311 1176 972 1270" style="list-style-type: none"> <li data-bbox="311 1176 909 1203">• Make sure that the battery power cable is correctly connected. <li data-bbox="311 1211 972 1270">• If this error is repeated frequently, contact the Service (see Section 16 "Contact", page 106).

Event number	Message, cause and corrective measures
9307	<p data-bbox="311 185 596 220">⚠ QUALIFIED PERSON</p> <p data-bbox="288 236 628 263">Battery system defective (ID [xx])</p> <p data-bbox="288 272 676 300">The battery has detected an internal error.</p> <p data-bbox="288 309 508 336">Corrective measures:</p> <ul data-bbox="311 344 1000 507" style="list-style-type: none"> <li data-bbox="311 344 900 395">• Note the displayed error ID and look for that ID in the battery manufacturer's error list. <li data-bbox="311 411 1000 462">• Carry out the corrective measures indicated in the battery manufacturer's error list. <li data-bbox="311 478 874 507">• Contact the Service (see Section 16 "Contact", page 106).
9308	<p data-bbox="311 515 596 550">⚠ QUALIFIED PERSON</p> <p data-bbox="288 566 969 593">Communication fault in battery system > Check battery connection</p> <p data-bbox="288 603 850 630">The inverter receives invalid data or no data from the battery.</p> <p data-bbox="288 639 508 667">Corrective measures:</p> <ul data-bbox="311 675 1006 911" style="list-style-type: none"> <li data-bbox="311 675 1006 726">• Make sure that the battery communication cable is properly connected to the inverter as well as to the battery. <li data-bbox="311 742 1006 769">• Ensure that the battery has been approved for operation with the inverter. <li data-bbox="311 785 726 812">• Ensure the perfect operation of the battery. <li data-bbox="311 828 1006 911">• If the battery communication cable has been properly connected and the correct operation of the battery is ensured, contact Service (see Section 16 "Contact", page 106).
9311	<p data-bbox="311 919 596 954">⚠ QUALIFIED PERSON</p> <p data-bbox="288 970 590 997">Battery cell overvoltage fault</p> <p data-bbox="288 1007 910 1034">The battery has detected an overvoltage of at least one battery cell.</p> <p data-bbox="288 1043 508 1070">Corrective measures:</p> <ul data-bbox="311 1078 950 1177" style="list-style-type: none"> <li data-bbox="311 1078 950 1129">• If a service contract with SMA Solar Technology AG exists, contact Service (see Section 16 "Contact", page 106). <li data-bbox="311 1145 788 1177">• If no service contract exists, contact your supplier.
9312	<p data-bbox="311 1185 596 1220">⚠ QUALIFIED PERSON</p> <p data-bbox="288 1236 603 1264">Battery cell undervoltage fault</p> <p data-bbox="288 1273 922 1300">The battery has detected an undervoltage of at least one battery cell.</p> <p data-bbox="288 1310 508 1337">Corrective measures:</p> <ul data-bbox="311 1345 950 1436" style="list-style-type: none"> <li data-bbox="311 1345 950 1396">• If a service contract with SMA Solar Technology AG exists, contact Service (see Section 16 "Contact", page 106). <li data-bbox="311 1412 788 1436">• If no service contract exists, contact your supplier.

Event number	Message, cause and corrective measures
9313	<p data-bbox="314 188 594 220">⚠ QUALIFIED PERSON</p> <p data-bbox="292 236 869 263">Low temperature fault in battery > Check installation site</p> <p data-bbox="292 272 977 325">The lower limit of the temperature range approved by the battery manufacturer has been exceeded.</p> <p data-bbox="292 336 508 360">Corrective measures:</p> <ul data-bbox="311 370 977 427" style="list-style-type: none"> <li data-bbox="311 370 977 427">• Make sure that the ambient conditions of the battery manufacturer are complied with.
9314	<p data-bbox="314 443 594 475">⚠ QUALIFIED PERSON</p> <p data-bbox="292 491 869 518">Overtemperature fault in battery > Check installation site</p> <p data-bbox="292 528 977 580">The upper limit of the temperature range approved by the battery manufacturer has been exceeded.</p> <p data-bbox="292 592 508 616">Corrective measures:</p> <ul data-bbox="311 625 977 683" style="list-style-type: none"> <li data-bbox="311 625 977 683">• Make sure that the ambient conditions of the battery manufacturer are complied with.
9315	<p data-bbox="314 699 594 730">⚠ QUALIFIED PERSON</p> <p data-bbox="292 746 552 774">Battery imbalancing fault</p> <p data-bbox="292 783 891 810">The states of charge of the individual battery cells differ too much.</p> <p data-bbox="292 820 508 844">Corrective measures:</p> <ul data-bbox="311 853 977 948" style="list-style-type: none"> <li data-bbox="311 853 977 906">• If a service contract with SMA Solar Technology AG exists, contact Service (see Section 16 "Contact", page 106). <li data-bbox="311 916 790 948">• If no service contract exists, contact your supplier.
9334	<p data-bbox="292 960 505 987">Battery charging test</p> <p data-bbox="292 997 768 1019">The battery test for charging the battery was started.</p>
9335	<p data-bbox="292 1032 516 1059">Discharge battery test</p> <p data-bbox="292 1069 794 1091">The battery test for discharging the battery was started.</p>
9336	<p data-bbox="314 1107 594 1139">⚠ QUALIFIED PERSON</p> <p data-bbox="292 1155 726 1182">Start conditions for battery test not fulfilled</p> <p data-bbox="292 1192 997 1244">The battery test cannot be started since the start conditions for the battery test are not fulfilled.</p> <p data-bbox="292 1256 508 1279">Corrective measures:</p> <ul data-bbox="311 1289 977 1428" style="list-style-type: none"> <li data-bbox="311 1289 977 1342">• Ensure that the battery is not charged above 98% and that the battery state of charge is not 2% above the lower discharge threshold. <li data-bbox="311 1351 726 1378">• Ensure the perfect operation of the battery. <li data-bbox="311 1388 835 1428">• Make sure that the grid connection conditions are met.

Event number	Message, cause and corrective measures
9337	<p>Charge battery test successful</p> <p>The battery test for charging the battery was carried out successfully.</p>
9338	<p>Battery discharging test successful</p> <p>The battery test for discharging the battery was carried out successfully.</p>
9339	<p>⚠ QUALIFIED PERSON</p> <p>Battery charging test failed</p> <p>The battery test for charging the battery was not carried out successfully. The power required in the test was not reached. The battery or the inverter limited the power due to normative requirements.</p> <p>Corrective measures:</p> <ul style="list-style-type: none"> • Carry out the test again at a later time. <p>If a power limitation occurred due to normative requirements, check whether the battery is charging after commissioning.</p>
9340	<p>⚠ QUALIFIED PERSON</p> <p>Battery discharging test failed</p> <p>The battery test for discharging the battery was not carried out successfully.</p> <p>Corrective measures:</p> <ul style="list-style-type: none"> • Make sure that the battery has been approved for operation with the inverter. • Carry out the test again at a later time. • Make sure that the inverter and the battery are not currently in a power reduction state.
9345	<p>⚠ QUALIFIED PERSON</p> <p>Battery charging for start process too low</p> <p>The state of charge of the battery is too low for the start process. The inverter can no longer charge the battery by itself. The battery must be charged immediately by a qualified person. This message causes a permanent operation inhibition, which must be reset manually.</p> <p>Corrective measures:</p> <ul style="list-style-type: none"> • If a service contract with SMA Solar Technology AG exists, contact Service (see Section 16 "Contact", page 106) and instruct them to manually charge the battery. • If no service contract exists, contact your supplier.

Event number	Message, cause and corrective measures
9347	<p>Battery is reporting event</p> <p>The battery has detected an internal error.</p> <p>Corrective measures:</p> <ul style="list-style-type: none"> • Note the displayed error ID and look for that ID in the battery manufacturer's error list. • Carry out the corrective measures indicated in the battery manufacturer's error list. • Contact the Service (see Section 16 "Contact", page 106).
10100	<p>Parameter [xx] set successfully. [xx] to [xx]</p> <p>The displayed parameter was successfully changed.</p>
10101	<p>Setting of parameter [xx] failed. [xx] to [xx]</p> <p>The displayed parameter was not changed.</p> <p>Corrective measures:</p> <ul style="list-style-type: none"> • Make sure thresholds of the parameters are complied with. • Change the parameter again.
10102	<p>Parameter [xx] set successfully. [xx] to [xx]</p> <p>The displayed parameter was successfully changed.</p>
10103	<p style="text-align: center;"> QUALIFIED PERSON</p> <p>Setting of parameter [xx] failed. [xx] to [xx]</p> <p>The displayed parameter was not changed.</p> <p>Corrective measures:</p> <ul style="list-style-type: none"> • Make sure thresholds of the parameters are complied with. • Change the parameter again.
10110	<p>Time synchronization failed: [x]</p> <p>No time information could be called up from the set NTP server.</p> <p>Corrective measures:</p> <ul style="list-style-type: none"> • Ensure that the NTP server was configured correctly. • Ensure that the inverter is integrated into a local network with Internet connection.
10118	<p>Parameter upload complete</p> <p>The configuration file was loaded successfully.</p>

Event number	Message, cause and corrective measures
10248 to 10249	<p data-bbox="288 180 992 209">Load reduced through device reduction or increase of query interval</p> <p data-bbox="288 217 1006 272">The network is busy. Data exchange between the devices is not at an optimum and is greatly delayed.</p> <p data-bbox="288 280 508 304">Corrective measures:</p> <ul data-bbox="309 312 865 419" style="list-style-type: none"> <li data-bbox="309 312 751 341">• Reduce the number of devices in the network. <li data-bbox="309 352 759 381">• If necessary, increase the data query intervals. <li data-bbox="309 392 865 419">• If necessary, reduce the number of devices in the network.
10250	<p data-bbox="309 435 596 472">⚠ QUALIFIED PERSON</p> <p data-bbox="288 483 723 512">[Interface]: package error rate [ok / high]</p> <p data-bbox="288 520 1006 608">The package error rate has changed. If the package error rate is high, the network is overloaded or the connection to the network switch or DHCP server (router) is disturbed.</p> <p data-bbox="288 616 837 644">Corrective measures if the package error rate is high:</p> <ul data-bbox="309 652 1009 810" style="list-style-type: none"> <li data-bbox="309 652 1009 740">• Ensure that with an Ethernet connection, the network cable and the network connector are not damaged and that the network connectors are correctly plugged. <li data-bbox="309 751 759 780">• If necessary, increase the data query intervals. <li data-bbox="309 791 865 818">• If necessary, reduce the number of devices in the network.
10251	<p data-bbox="288 826 967 882">[Interface]: communication status goes to [OK / Warning / Error / Not connected]</p> <p data-bbox="288 890 983 946">The communication status to the network switch or DHCP server (router) has changed. An additional error message may be displayed.</p>
10252	<p data-bbox="309 962 596 999">⚠ QUALIFIED PERSON</p> <p data-bbox="288 1010 670 1038">[Interface]: communication disrupted</p> <p data-bbox="288 1046 686 1075">There is no valid signal on the network line.</p> <p data-bbox="288 1083 508 1107">Corrective measures:</p> <ul data-bbox="309 1115 1009 1273" style="list-style-type: none"> <li data-bbox="309 1115 1009 1203">• Ensure that with an Ethernet connection, the network cable and the network connector are not damaged and that the network connectors are correctly plugged. <li data-bbox="309 1214 947 1273">• Ensure that the DHCP server (router) and any network switches are signaling correct operation.

Event number	Message, cause and corrective measures
10253	<p>⚠ QUALIFIED PERSON</p> <p>[Interface]: connection speed goes to [100 Mbit / 10 Mbit] The data transfer rate has changed. The cause for the status [10 Mbit] can be a defective plug, a defective cable or the pulling or plugging of the network connector.</p> <p>Corrective measures if the status is [10 Mbit]:</p> <ul style="list-style-type: none"> • Ensure that with an Ethernet connection, the network cable and the network connector are not damaged and that the network connectors are correctly plugged. • Ensure that the DHCP server (router) and any network switches are signaling correct operation.
10254	<p>⚠ QUALIFIED PERSON</p> <p>[Interface]: duplex mode goes to [Full / Half] The duplex mode (data transfer mode) has changed. The cause for the status [Half] can be a defective plug, a defective cable or the pulling or plugging of the network connector.</p> <p>Corrective measures if the status is [Half]:</p> <ul style="list-style-type: none"> • Ensure that with an Ethernet connection, the network cable and the network connector are not damaged and that the network connectors are correctly plugged. • Ensure that the DHCP server (router) and any network switches are signaling correct operation.
10255	<p>[Interface]: Network load OK The network load has returned to a normal range after being busy.</p>
10282	<p>[User group]-Login via [protocol] locked After several incorrect login attempts, login has been blocked for a limited time. In this case, the User login will be blocked for 15 minutes, the Grid Guard login for 12 hours.</p> <p>Corrective measures:</p> <ul style="list-style-type: none"> • Wait until the given time has expired and then retry login.
10283	<p>WLAN module faulty The WLAN module integrated in the inverter is defective.</p> <p>Corrective measures:</p> <ul style="list-style-type: none"> • Contact the Service (see Section 16 "Contact", page 106).

Event number	Message, cause and corrective measures
10284	<p data-bbox="311 183 593 215">⚠ QUALIFIED PERSON</p> <p data-bbox="288 231 604 263">No WLAN connection possible</p> <p data-bbox="288 271 985 327">The inverter does not currently have a WLAN connection to the selected network.</p> <p data-bbox="288 335 504 359">Corrective measures:</p> <ul data-bbox="311 367 996 582" style="list-style-type: none"> <li data-bbox="311 367 996 454">• Ensure that the SSID, the WLAN password and the encryption method have been entered correctly. The encryption method is specified by your WLAN router or WLAN Access Point and can be changed there. <li data-bbox="311 462 996 518">• Ensure that the WLAN router or WLAN Access Point is in range and is signaling correct operation. <li data-bbox="311 526 996 582">• If this message is displayed often, improve the WLAN connection by using a WLAN repeater.
10285	<p data-bbox="288 598 599 630">WLAN connection established</p> <p data-bbox="288 638 884 662">Connection to the selected WLAN network has been established.</p>
10286	<p data-bbox="311 678 593 710">⚠ QUALIFIED PERSON</p> <p data-bbox="288 726 520 758">WLAN connection lost</p> <p data-bbox="288 766 868 790">The inverter has lost WLAN connection to the selected network.</p> <p data-bbox="288 798 504 821">Corrective measures:</p> <ul data-bbox="311 829 980 997" style="list-style-type: none"> <li data-bbox="311 829 980 861">• Ensure that the WLAN router or WLAN Access Point is still active. <li data-bbox="311 869 980 925">• Ensure that the WLAN router or WLAN Access Point is in range and is signaling correct operation. <li data-bbox="311 933 980 997">• If this message is displayed often, improve the WLAN connection by using a WLAN repeater.
10339	<p data-bbox="288 1013 509 1045">Webconnect enabled</p> <p data-bbox="288 1053 980 1109">The inverter can communicate with Sunny Portal without an additional SMA communications product (e.g. Sunny Home Manager).</p>
10340	<p data-bbox="288 1117 515 1149">Webconnect disabled</p> <p data-bbox="288 1157 996 1236">The Webconnect function has been switched off. This means that the inverter can not communicate with Sunny Portal without an additional SMA communications product (e.g. Sunny Home Manager).</p> <ul data-bbox="311 1244 991 1300" style="list-style-type: none"> <li data-bbox="311 1244 991 1300">• If the inverter is to communicate with Sunny Portal without an additional SMA communication product, switch the Webconnect function on.

Event number	Message, cause and corrective measures
10341	<p>Webconnect error: no connection</p> <p>It is likely that there is an error in the network settings.</p> <p>Corrective measures:</p> <ul style="list-style-type: none"> • Check the network components (DLAN, WLAN Access Point etc.). • Ensure that the following ports are not blocked: <ul style="list-style-type: none"> - Registrar: ied.sma.de:9523 - Proxy: ied.sma.de:9523 - Stun: stun.sma.de:3478 - Domain: ied.sma.de (for SIP URI)
10343	<p>Webconnect error: Default gateway not configured</p> <p>It is likely that there is an error in the network settings.</p> <p>Corrective measures:</p> <ul style="list-style-type: none"> • Check the network components (DLAN, WLAN Access Point etc.). • Ensure that the following ports are not blocked: <ul style="list-style-type: none"> - Registrar: ied.sma.de:9523 - Proxy: ied.sma.de:9523 - Stun: stun.sma.de:3478 - Domain: ied.sma.de (for SIP URI)
10344	<p>Webconnect error: DNS server not configured</p> <p>It is likely that there is an error in the network settings.</p> <p>Corrective measures:</p> <ul style="list-style-type: none"> • Check the network components (DLAN, WLAN Access Point etc.). • Ensure that the following ports are not blocked: <ul style="list-style-type: none"> - Registrar: ied.sma.de:9523 - Proxy: ied.sma.de:9523 - Stun: stun.sma.de:3478 - Domain: ied.sma.de (for SIP URI)

Event number	Message, cause and corrective measures
10345	<p>No reply to DNS request</p> <p>It is likely that there is an error in the network settings.</p> <p>Corrective measures:</p> <ul style="list-style-type: none"> • Check the network components (DLAN, WLAN Access Point etc.). • Ensure that the following ports are not blocked: <ul style="list-style-type: none"> - Registrar: ied.sma.de:9523 - Proxy: ied.sma.de:9523 - Stun: stun.sma.de:3478 - Domain: ied.sma.de (for SIP URI)
10346	<p>SIP proxy DNS resolution failed</p> <p>It is likely that there is an error in the network settings.</p> <p>Corrective measures:</p> <ul style="list-style-type: none"> • Check the network components (DLAN, WLAN Access Point etc.). • Ensure that the following ports are not blocked: <ul style="list-style-type: none"> - Registrar: ied.sma.de:9523 - Proxy: ied.sma.de:9523 - Stun: stun.sma.de:3478 - Domain: ied.sma.de (for SIP URI)
10347	<p>Stun server DNS resolution failed</p> <p>It is likely that there is an error in the network settings.</p> <p>Corrective measures:</p> <ul style="list-style-type: none"> • Check the network components (DLAN, WLAN Access Point etc.). • Ensure that the following ports are not blocked: <ul style="list-style-type: none"> - Registrar: ied.sma.de:9523 - Proxy: ied.sma.de:9523 - Stun: stun.sma.de:3478 - Domain: ied.sma.de (for SIP URI)

Event number	Message, cause and corrective measures
10348	<p>Webconnect error: No reply to request to STUN server</p> <p>It is likely that there is an error in the network settings.</p> <p>Corrective measures:</p> <ul style="list-style-type: none"> • Check the network components (DLAN, WLAN Access Point etc.). • Ensure that the following ports are not blocked: <ul style="list-style-type: none"> - Registrar: ied.sma.de:9523 - Proxy: ied.sma.de:9523 - Stun: stun.sma.de:3478 - Domain: ied.sma.de (for SIP URI)
10349	<p>Webconnect error: No reply to SIP option packs</p> <p>It is likely that there is an error in the network settings or a Sunny Portal maintenance message is present.</p> <p>Corrective measures:</p> <ul style="list-style-type: none"> • If a Sunny Portal maintenance message is present, wait until the maintenance has been completed. • Check the network components (DLAN, WLAN Access Point etc.). • Ensure that the following ports are not blocked: <ul style="list-style-type: none"> - Registrar: ied.sma.de:9523 - Proxy: ied.sma.de:9523 - Stun: stun.sma.de:3478 - Domain: ied.sma.de (for SIP URI)
10350	<p>Webconnect error: Registration rejected by SIP registrar</p> <p>It is likely that there is an error in the network settings.</p> <p>Corrective measures:</p> <ul style="list-style-type: none"> • Check the network components (DLAN, WLAN Access Point etc.). • Ensure that the following ports are not blocked: <ul style="list-style-type: none"> - Registrar: ied.sma.de:9523 - Proxy: ied.sma.de:9523 - Stun: stun.sma.de:3478 - Domain: ied.sma.de (for SIP URI)

Event number	Message, cause and corrective measures
10351	<p>Unknown SIP registry</p> <p>It is likely that there is an error in the network settings.</p> <p>Corrective measures:</p> <ul style="list-style-type: none"> • Check the network components (DLAN, WLAN Access Point etc.). • Ensure that the following ports are not blocked: <ul style="list-style-type: none"> - Registrar: ied.sma.de:9523 - Proxy: ied.sma.de:9523 - Stun: stun.sma.de:3478 - Domain: ied.sma.de (for SIP URI)
10352	<p>Webconnect error: Faulty communication</p> <p>It is likely that there is an error in the network settings or a Sunny Portal maintenance message is present.</p> <p>Corrective measures:</p> <ul style="list-style-type: none"> • If a Sunny Portal maintenance message is present, wait until the maintenance has been completed. • Check the network components (DLAN, WLAN Access Point etc.). • Ensure that the following ports are not blocked: <ul style="list-style-type: none"> - Registrar: ied.sma.de:9523 - Proxy: ied.sma.de:9523 - Stun: stun.sma.de:3478 - Domain: ied.sma.de (for SIP URI)
10353	<p>Webconnect error: registration of the SIP registry has not responded</p> <p>It is likely that there is an error in the network settings or a Sunny Portal maintenance message is present.</p> <p>Corrective measures:</p> <ul style="list-style-type: none"> • If a Sunny Portal maintenance message is present, wait until the maintenance has been completed. • Check the network components (DLAN, WLAN Access Point etc.). • Ensure that the following ports are not blocked: <ul style="list-style-type: none"> - Registrar: ied.sma.de:9523 - Proxy: ied.sma.de:9523 - Stun: stun.sma.de:3478 - Domain: ied.sma.de (for SIP URI)

Event number	Message, cause and corrective measures
10420	<p>Internal consumption control was started</p> <p>The battery is automatically charged or discharged depending on the purchased electricity or the grid feed-in.</p>
10421	<p>Internal consumption control was stopped</p> <p>The automatic charging or discharging of the battery stopped due to an external control command.</p>
10422	<p>Only charging operation in internal consumption mode</p> <p>The battery is charged only when increased self-consumption is active. The battery is only charged again once there is sufficient PV power in the system.</p>
10425	<p>The device switches off</p> <p>The battery is switched off in order to protect against deep discharge. The inverter can only be recommissioned once it has been disconnected from the utility grid.</p>
10517	<p>Dynamic active power limitation started.</p> <p>The inverter limits the active power of the PV inverters to the set limit.</p>
10518	<p>Dynamic active power limitation terminated.</p> <p>The inverter terminated the active power limitation of the PV inverters.</p>
10520	<p>⚠ QUALIFIED PERSON</p> <p>Supplied power: [xx] W (permitted value: [xx] W)</p> <p>The set active power limitation cannot be met.</p> <p>Corrective measures:</p> <ul style="list-style-type: none"> • Ensure that the correct active power limitation has been configured. • Ensure that the PV inverters have been configured correctly. • Ensure that the communication between battery inverter and PV inverter functions perfectly. • Ensure that no external feeders are in the system.
10521	<p>Active power was limited today for [xx] minutes.</p> <p>The active power limitation of the PV inverters was limited for the specified time.</p>
27103	<p>Set parameter</p> <p>The parameter change has been adopted.</p>
27104	<p>Parameters set successfully</p> <p>The parameter changes were successfully adopted.</p>
27107	<p>Update file OK</p> <p>The update file is suitable for this inverter and its components and is fully available for the next update step.</p>

Event number	Message, cause and corrective measures
27301	Update communication The inverter is updating the communication component.
27302	Update main CPU The inverter is updating the inverter component.
27312	Update completed The inverter has successfully completed the update.
27336	Battery management system The inverter is updating the battery.
29001	Inst. code valid The entered Grid Guard code is valid. Protected parameters have now been unlocked and you can adjust the parameters. The parameters will be automatically locked again after ten feed-in hours.
29004	Grid parameters unchanged Changing the grid parameters is not possible.

12.3 Updating the Firmware

QUALIFIED PERSON

If the automatic firmware update function for the inverter or for the battery has not been enabled in the communication product (e.g. Sunny Home Manager) or in Sunny Portal, you can update the inverter firmware and/or the battery firmware as described in the following. The inverter and the battery each have an individual firmware package. If the firmware of both the inverter and the battery is to be updated, the inverter firmware is to be updated first.

Faulty firmware update due to disconnecting the inverter from the utility grid.

The inverter must be connected to the utility grid during the firmware update. This will ensure a proper firmware update.

- Do not disconnect the inverter from the utility grid during the firmware update.

Requirements:

- To update the inverter firmware, the update file with the desired inverter firmware must be available. The update file is, for example, available for download on the product page of the inverter at www.SMA-Solar.com. To download the update file, it is necessary to enter the serial number of the inverter.
- To update the battery firmware, the update file with the desired battery firmware must be available. The update file is, for example, available for download on the product page of the inverter at www.SMA-Solar.com. To download the update file, it is necessary to enter the serial number of the inverter.

Procedure:

1. Activate the user interface (see Section 8.1, page 48).
2. Log into the user interface (see Section 8.2, page 51).
3. Update the inverter firmware:
 - Select the menu **Device Configuration**.
 - In the inverter row, click on the gear icon and select **Update firmware**.
 - Select [**Browse**] and select the update file for the inverter.
 - Select **Update firmware**.
 - Follow the instructions in the dialog.
 - The inverter firmware has been updated.
4. Update the battery firmware:
 - Select the menu **Device Configuration**.
 - In the inverter row, click on the gear icon and select **Update firmware**.
 - Select [**Browse**] and select the update file for the battery.
 - Select **Update firmware**.
 - Follow the instructions in the dialog.
 - The battery firmware has been updated.

13 Decommissioning the Inverter

⚠ QUALIFIED PERSON

⚠ CAUTION

Risk of injury when lifting the inverter, or if it is dropped

The inverter weighs 9 kg. There is risk of injury if the inverter is lifted incorrectly or dropped while being transported or when attaching it to or removing it from the wall mounting bracket.

- Transport and lift the inverter carefully.

Procedure:

1. ⚠ DANGER

Danger to life due to high voltages

- Disconnect the inverter from all voltage sources (see Section 10, page 67).

2. ⚠ CAUTION

Risk of burns due to hot enclosure parts

- Wait 30 minutes for the enclosure to cool down.

3. Remove the conductors from the connecting terminal plate for the connection of the battery communication cable.

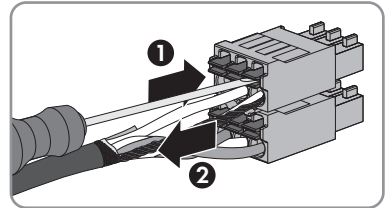

4. Remove the conductors from the DC connectors (see Section 6.3.3, page 35).

5. Remove the L, N and grounding conductor from the connecting terminal plate for the AC connection. To do this, stick a flat-blade screwdriver (blade width: 3 mm) as far as it can go into the rectangular opening behind the terminal and remove the conductors from the terminals.

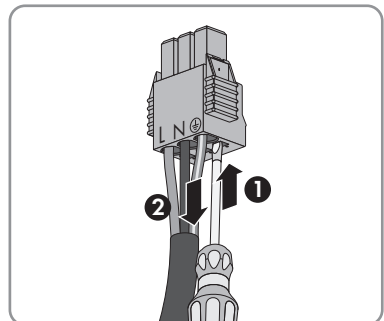

6. Tighten the connection cap to the inverter using the three screws and a Torx screwdriver (TX20) (torque: 3.5 Nm).

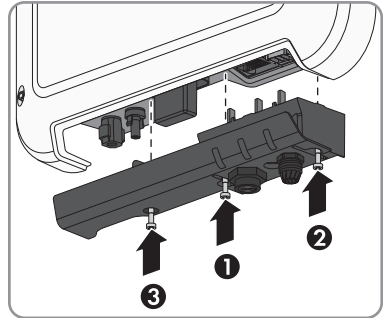

7. Screw the swivel nuts onto the cable glands on the connection cap.

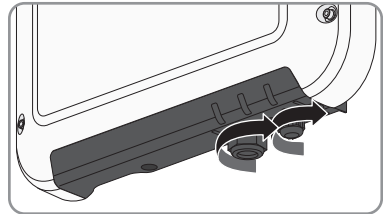

8. If an additional grounding or an equipotential bonding is connected to the inverter, remove the cap screw using a Torx screwdriver (TX 25) and remove the grounding cable.

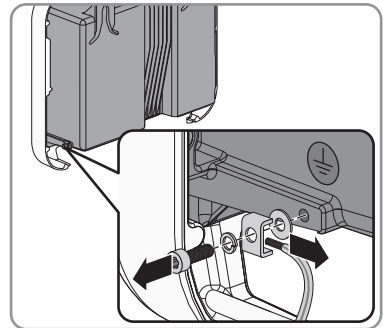

9. Using a ratchet or a box wrench, slightly loosen the screws for attaching the inverter.

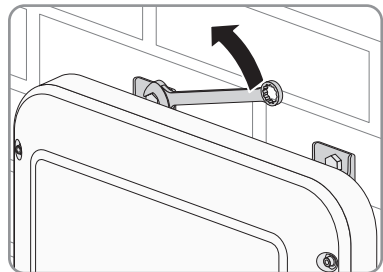

10. Remove the inverter from the screws using the metal brackets.

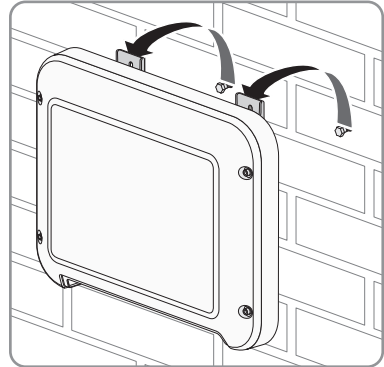

11. If the inverter is to be stored or shipped, pack the inverter. Use the original packaging or packaging that is suitable for the weight and dimensions of the inverter.
12. Dispose of the inverter in accordance with the locally applicable disposal regulations for electronic waste.

14 Spare Parts

You will find the spare parts for your product in the following overview. If required, these can be ordered from SMA Solar Technology AG or your distributor.

Designation	Brief description	SMA order number
Enclosure lid	Enclosure lid white	101840-00.01
Connection cap	Connection cap for covering the connection area	102143-00.01
accessory kit	Accessory kit with DC connectors, grounding terminal for additional grounding, connecting terminal plate for the AC connection and connecting terminal plate for the connection of the battery communication cable	101439-00.01

15 Technical Data

AC Connection

Rated power at 230 V, 50 Hz	2500 W
Maximum apparent AC power at $\cos \varphi = 1$	2500 VA
Rated grid voltage	230 V
Nominal AC voltage	220 V / 230 V / 240 V
AC voltage range*	180 V to 280 V
Nominal AC current at 220 V	11 A
Nominal AC current at 230 V	11 A
Nominal AC current at 240 V	10.5 A
Maximum AC current	11 A
Total harmonic distortion of the AC current at total harmonic distortion of the AC voltage < 2%, and the AC power > 50% of the rated power	≤3 %
Maximum output current under fault conditions	19 A
Inrush current	< 20% of the nominal AC current for a maximum of 10 ms
Rated power frequency	50 Hz
AC power frequency*	50 Hz / 60 Hz
Operating range at AC power frequency 50 Hz	45 Hz to 55 Hz
Operating range at AC power frequency 60 Hz	55 Hz to 65 Hz
Power factor at rated power	1
Displacement power factor $\cos \varphi$, adjustable	0.8 overexcited to 1 to 0.8 underexcited
Feed-in phases	1
Phase connection	1
Overvoltage category in accordance with IEC 60664-1	III

* depending on the configured country data set

Battery DC Input

Maximum DC power at $\cos \varphi = 1$	2650 W
Maximum DC Voltage	500 V
Voltage range	100 V to 500 V
DC rated voltage	360 V

Minimum DC voltage	100 V
DC start voltage	100 V
Maximum DC current	10 A
Maximum short-circuit current	18 A
Battery type*	Li-ion
Overvoltage category in accordance with IEC 60664-1	III

* Only use batteries approved by SMA Solar Technology AG (see list of approved batteries at www.SMA-Solar.com)

Protective Devices

DC reverse polarity protection	Not available
Input-side disconnection point	Not available
AC short-circuit current capability	Current control
Ground fault monitoring	Available
Grid monitoring	SMA Grid Guard 6
Maximum permissible fuse protection	16 A
All-pole sensitive residual-current monitoring unit	Available

General Data

Width x height x depth with connection cap	450 mm x 357 mm x 122 mm
Weight	9.2 kg
Length x width x height of the packaging	597 mm x 399 mm x 238 mm
Weight including packaging	11.5 kg
Climatic category in accordance with IEC 60721-3-4	4K4H
Environmental category	Outdoors
Pollution degree outside the inverter	3
Pollution degree inside the inverter	2
Operating temperature range	-40°C to +60°C
Maximum permissible value for relative humidity, non-condensing	100 %
Maximum operating altitude above mean sea level	3000 m
Noise emission, typical	< 25 dB

Self-consumption in standby operation	< 2 W
Self-consumption without the load necessary to supply the battery	< 10 W
Maximum data volume per inverter with Speedwire/Webconnect	550 MB/month
Additional data volume when using the Sunny Portal live interface	600 kB/hour
WLAN range in free-field conditions	100 m
Quantity maximum detectable WLAN networks	32
Topology	Transformerless
Cooling method	Convection
Degree of protection in accordance with IEC 60529	IP65
Protection class in accordance with IEC 62103	I
Grid configurations	TN-C, TN-S, TN-CS, TT (if $V_{N,PE} < 30$ V), IT, Delta IT, split phase
National standards and approvals, as per 02/2016*	AS 4777.2:2015, C10/11/2012, CEI 0-21, EN 50438:2013, G83/2, IEC 61727, IEC 62109-2, NEN-EN50438, NRS097, PPC, PPDS, RD 1699, VDE-AR-N 4105, VDE 0126-1-1, VFR2014

* **IEC 62109-2:** In order to meet the requirements of this standard, there must be a link to Sunny Portal with the fault alert via e-mail activated.

Climatic Conditions

Installation in accordance with IEC 60721-3-4, Class 4K4H

Extended temperature range	-40 °C to +60 °C
Extended humidity range	0% to 100%
Extended air pressure range	79.5 kPa to 106 kPa

Transport in accordance with IEC 60721-3-4, Class 2K3

Extended temperature range	-25 °C to +70 °C
----------------------------	------------------

Equipment

DC connection	DC connector
AC connection	Spring-cage terminal
Battery communication	CAN bus

Speedwire interface	As standard
Webconnect function	As standard
WLAN interface	As standard

Torques

Screws for mounting	Hand-tight
Swivel nut of the DC connector	2 Nm
Swivel nut of the cable gland for the AC connection.	Hand-tight
Swivel nut cable gland network and battery communication connection	Hand-tight
Screws for attaching the connection cap	3.5 Nm \pm 0.3 Nm
Screw for additional grounding	6 Nm \pm 0.3 Nm
Screws for attaching the enclosure lid	6 Nm \pm 0.3 Nm

Data Storage Capacity

Energy yields in the course of the day	63 days
Daily yields	30 years
Event messages for users	1000 events
Event messages for installers	1000 events

Efficiency

Maximum efficiency, η_{max}	97.0 %
European weighted efficiency, η_{EU}	96.5 %

16 Contact

If you have technical problems with our products, please contact the SMA Service Line. We require the following information in order to provide you with the necessary assistance:

- Inverter device type
- Inverter serial number
- Inverter firmware version
- Special country-specific settings of the inverter (if applicable)
- Mounting location and altitude of the inverter
- Inverter message
- Optional equipment, e.g. communication products
- Type of battery connected
- Firmware version of the battery

Danmark	SMA Solar Technology AG	Belgien	SMA Benelux BVBA/SPRL
Deutschland	Niestetal	Belgique	Mechelen
Österreich	Sunny Boy, Sunny Mini Central,	België	+32 15 286 730
Schweiz	Sunny Tripower: +49 561 9522-1499	Luxemburg	SMA Online Service Center: www.SMA-Service.com
	Monitoring Systems (Kommunikationsprodukte): +49 561 9522-2499	Luxembourg	
	Fuel Save Controller (PV-Diesel-Hybridsysteme): +49 561 9522-3199	Nederland	
	Sunny Island, Sunny Boy Storage, Sunny Backup, Hydro Boy: +49 561 9522-399	Česko	SMA Service Partner
	Sunny Central, Sunny Central Storage: +49 561 9522-299	Magyarország	TERMS a.s.
	SMA Online Service Center: www.SMA-Service.com	Slovensko	+420 387 6 85 111 SMA Online Service Center: www.SMA-Service.com
France	SMA France S.A.S. Lyon +33 472 22 97 00	Türkiye	SMA Service Partner DEKOM Ltd. Şti. +90 24 22430605 SMA Online Service Center: www.SMA-Service.com
	SMA Online Service Center : www.SMA-Service.com	Ελλάδα	SMA Service Partner
		Κύπρος	AKTOR FM. Αθήνα +30 210 8184550 SMA Online Service Center: www.SMA-Service.com

España Portugal	SMA Ibérica Tecnología Solar, S.L.U. Barcelona +34 935 63 50 99 SMA Online Service Center: www.SMA-Service.com	United Kingdom	SMA Solar UK Ltd. Milton Keynes +44 1908 304899 SMA Online Service Center: www.SMA-Service.com
Italia	SMA Italia S.r.l. Milano +39 02 8934-7299 SMA Online Service Center: www.SMA-Service.com	Bulgaria România Slovenija Hrvatska	SMA Service Partner Renovatio Solar +40 372 756 599 SMA Online Service Center: www.SMA-Service.com
United Arab Emirates	SMA Middle East LLC Abu Dhabi +971 2234 6177 SMA Online Service Center: www.SMA-Service.com	India	SMA Solar India Pvt. Ltd. Mumbai +91 22 61713888
ไทย	SMA Solar (Thailand) Co., Ltd. บริษัท สแม โซลาร์ (ไทยแลนด์) จำกัด +66 2 670 6999	대한민국	SMA Technology Korea Co., Ltd. 서울 +82-2-520-2666
South Africa	SMA Solar Technology South Africa Pty Ltd. Cape Town 08600SUNNY (08600 78669) International: +27 (0)21 826 0600 SMA Online Service Center: www.SMA-Service.com	Argentina Brasil Chile Perú	SMA South America SPA Santiago de Chile +562 2820 2101
Australia	SMA Australia Pty Ltd. Sydney Toll free for Australia: 1800 SMA AUS (1800 762 287) International: +61 2 9491 4200	Other countries	International SMA Service Line Niestetal 00800 SMA SERVICE (+800 762 7378423)

17 EU Declaration of Conformity

within the scope of the EU directives

- Electromagnetic compatibility 2014/30/EU (L 96/79-106, March 29, 2014) (EMC)
- Low Voltage Directive 2014/35/EU (L 96/357-374, March 29, 2014) (LVD)
- Radio and telecommunications terminal equipment (R&TTE) 1999/05/EC



SMA Solar Technology AG confirms herewith that the inverters described in this document are in compliance with the fundamental requirements and other relevant provisions of the above-mentioned directives. The entire EU Declaration of Conformity can be found at www.SMA-Solar.com.

